

Fig. 5-35 Cross Sectional View

POWER BRAKES—MORaine

GENERAL DESCRIPTION

The Moraine Power brake unit can be identified by the cast iron master cylinder and cast iron filler cap (Fig. 5-39). The Bendix Power brake unit can be identified by the die-cast hydraulic cylinder and pressed steel filler cap (Fig. 5-17).

The Moraine power brake is a combined vacuum and hydraulic unit for power braking, utilizing engine intake manifold vacuum, and atmospheric pressure for its operation (Fig. 5-12). It is a self-contained unit requiring no external rods or levers exposed to dirt and moisture. This power brake unit replaces the master cylinder only. Other parts of the brake system are the same as with standard brake. Two external line connections to the power brake are necessary. One is a vacuum connection to the carburetor (and vacuum reservoir). The other is a hydraulic connection into the hydraulic brake system.

The power brake system provides reduced pedal travel compared to the conventional braking system. The reduced pedal travel brings the height of the pedal down to approximately that of the accelerator

pedal, permitting the driver to shift his toe from one pedal to the other without lifting his heel from the floor. Lighter pedal pressures are also obtained for normal stops.

Design of the Power Brake is such that, in case of engine failure and consequent loss of engine vacuum, several applications of the brakes are possible by using vacuum supply in vacuum reservoir. In case of complete vacuum loss, brakes can be applied in the conventional manner, although more effort is required due to loss of power assist.

CONSTRUCTION (FIG. 5-35)

The unit is composed of two main sections, the Vacuum Power Cylinder and the Hydraulic Master Cylinder.

The Vacuum Power Cylinder contains the power piston assembly (4), which houses the control valve and reaction mechanism, and the power piston return spring (5). The control valve is made up of the air valve (26) and the floating control valve assembly

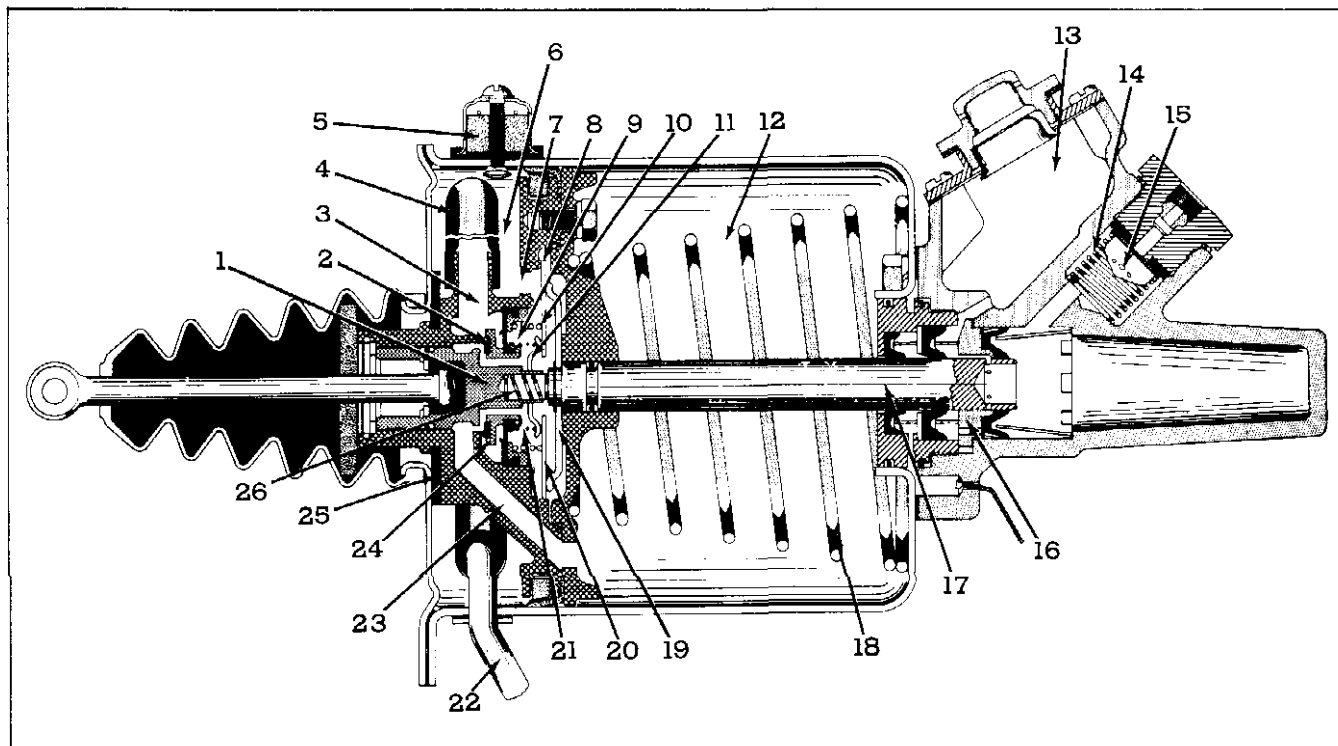

Fig. 5-36 Released Position

(25). The reaction mechanism consists of a hydraulic piston reaction plate (21), a series of levers (23), and a valve reaction plate (24). On the outside of the vacuum cylinder housing is an air filter (3) and a tube (22) for connection to the vacuum source. The push rod (1), which operates the air valve, projects out the end of the vacuum power cylinder housing through a felt silencer (2) and a boot (27).

Inside the hydraulic master cylinder is a cylinder plug assembly (6) into which are pressed a vacuum seal (7) and a secondary seal (8). A primary seal (11) is pressed into the bore of the casting. Through these there is a hydraulic master cylinder plunger (20) which is free to slide in the power piston and is secured to a hydraulic plunger reaction plate (21). A bearing (16) for this plunger also backs up the primary seal (11). A fluid reservoir (12) is cast integrally with the master cylinder and supplies fluid to the space between the primary and secondary seals through a hole in the casting (9). When the brake pedal is released quickly, the master cylinder plunger (20) returns immediately to the released position. If fluid from the lines can not return as quickly as the master cylinder plunger, compensation is provided for by a flow of fluid from the space between the primary and secondary cups through the holes (18) in the bearing. The excess fluid in the system can

flow back through a series of small radial holes (15) in the counterbored end of the master cylinder plunger, through grooves in the bearing (10), and hence back to the reservoir.

Any pressure between the vacuum seal (7) and the secondary seal (8) is vented through radial holes (19) in the cylinder plug (6) to atmosphere through a hole in the casting which is kept open by a jiggle pin (17). Connection is made to the wheel cylinder through the headnut (14) and a conventional check valve (13).

PRINCIPLES OF OPERATION

RELEASE POSITION (FIG. 5-36)

A vacuum check valve is connected to the engine intake manifold to prevent loss of vacuum when manifold vacuum falls below that in the power brake system. A tube leads from the check valve to a vacuum reservoir and to the vacuum inlet tube (22) on the power brake unit. From the end of this tube inside the housing, a coiled rubber hose (4) leads to the power piston, where a drilled passage communicates with the chamber (3). At this point the vacuum is stopped by the annular rubber seat (2) on the floating control valve which is pressed against

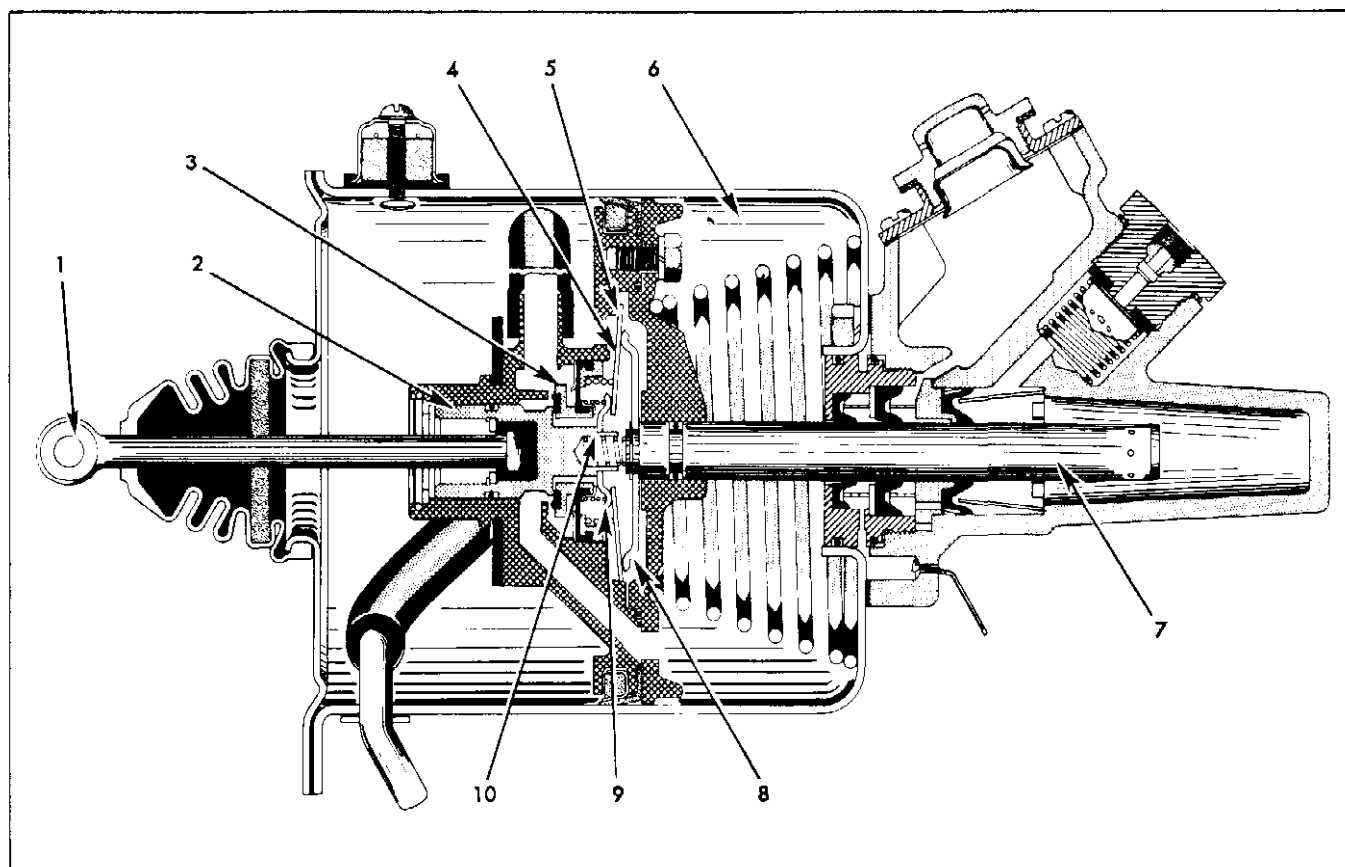

Fig. 5-37 Apply Position

a flat surface on the power piston by the valve diaphragm spring (21) and atmospheric pressure.

Atmospheric pressure comes through the air filter (5) into the space (6) and on into the space (9) through holes (7) in the power piston. From here it can flow around the open annular seat on the air valve (1) and through the passages (23) to the space ahead of the power piston at (12). The air valve (1) is held away from the floating control valve (24) by the valve return spring (26).

The valve reaction plate (11) is held against the reaction levers (20) by the valve diaphragm spring (21) and this with the reaction spring (10), holds the hydraulic plunger reaction plate (19) against its stop and the levers (20) against the pivot point on power piston (8).

Under these conditions the power piston is balanced by atmospheric pressure on both sides and is held against the rubber stop washer (25) by the large coil return spring (18).

In this position the radial holes in the counter-bored end of the hydraulic master cylinder plunger (17) are open to the grooves on the inner diameter

of the bearing (16) and fluid can flow freely in either direction between the hydraulic cylinder and the fluid reservoir (13). A residual pressure is maintained in the brake lines by the check valve (15) and its spring (14).

APPLYING (FIG. 5-37)

As the brake pedal is depressed, the push rod (1) carries the air valve (2) forward until its seat contacts the floating control valve (3) at which point the atmospheric pressure is sealed off and cannot enter space (6). Further movement carries the floating valve away from its seat on the power piston and opens the space (6) to the vacuum source while the air valve remains closed. Thus, the air is exhausted in space (6) and the atmospheric pressure on the left side of the power piston starts moving the piston to the right.

As the piston moves it carries the hydraulic master cylinder plunger (7) to the right until the radial holes in the master cylinder plunger pass the lip of the primary cup, and hydraulic pressure starts to build up in the hydraulic system. As this takes place the pressure on the end of the master cylinder

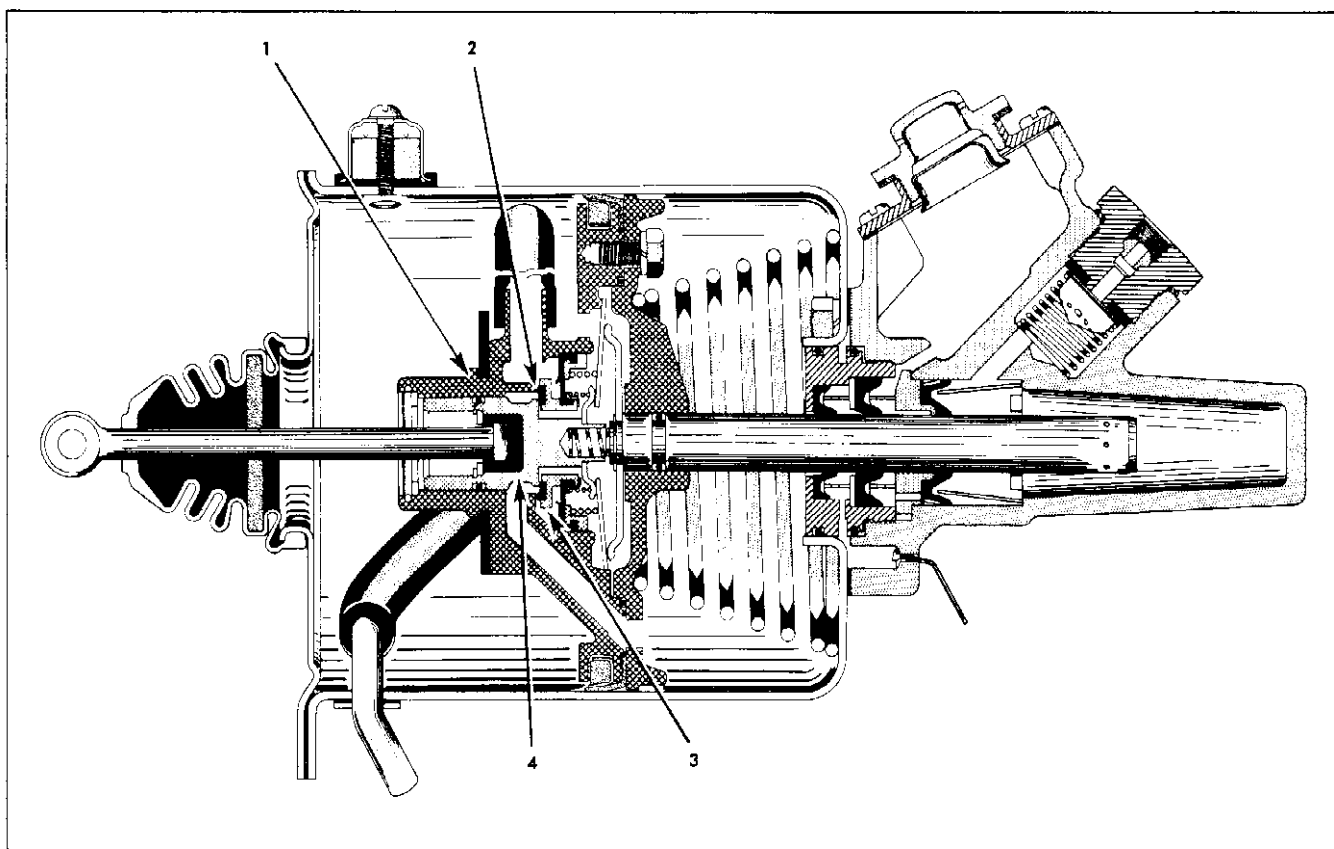

Fig. 5-38 Holding Position

plunger causes the hydraulic plunger reaction plate (8) to move away from its stop and press against the reaction levers (4). The levers in turn swing around their pivots (5) and push the valve reaction plate (9) back against the shoulder on the air valve at (10). In this manner approximately 40% of the load on the hydraulic master cylinder plunger is transferred through the air valve and the push rod to the brake pedal and gives the operator a feel proportional to the degree of brake application. Thus, about 40% of the load on the hydraulic master cylinder plunger (7) is supplied by the operator's foot on the brake pedal, the remainder being supplied by atmospheric pressure on the left side of the power piston.

HOLDING (FIG. 5-38)

When the desired pressure on the brake pedal is reached the power piston (1) has moved down until its flat surface at (2) again rests on the annular rubber seat of the floating control valve (3). At this point both the air valve (4) and the floating control valve (3) are closed and no further movement takes place until the load on the pedal is either increased or decreased.

RELEASING (FIG. 5-36)

As the pressure on the pedal is released, the valve return spring (26) forces the air valve (1) to the left. The floating control valve (24) remains seated on the power piston, shutting off the vacuum to space (12) and the air valve moves away from the floating control valve (24) allowing air to flow into the space (12). Since both sides of the power piston are now open to atmospheric pressure, the spring (18) forces the piston back against the rubber stop (25). As the power piston and hydraulic master cylinder plunger move back, the fluid from the wheel cylinder flows back into the hydraulic master cylinder through the check valve (15) and into the reservoir through the radial holes in the counterbored end of the hydraulic master cylinder plunger (17).

VACUUM FAILURE (FIG. 5-35)

In case of an interruption of the vacuum source, as the pedal is pushed down, the end of the air valve contacts the end of the hydraulic master cylinder plunger and it is forced down by manual pressure alone. In this case the pedal pressure for a given brake application is much greater.

PERIODIC SERVICE

Each time the car is in the service department the brake pedal should be observed. Brakes should be adjusted any time the pedal pad to floor clearance is less than 1" with brakes applied and engine running.

The power brake piston packing is lubricated at the time of original assembly and needs no further lubrication. CAUTION: *Do not lubricate air valve.*

ADJUSTMENTS ON CAR

There are no special adjustments required on Pontiac cars equipped with power brakes. Any time the brake pedal goes to within 1" from floor (floor mat to underside of pedal pad) brake should be adjusted as outlined under "Adjustments on Car", page 5-3. The following inspections must be made on cars with power brakes at the time the brakes are adjusted.

1. Check vacuum lines and connections between intake manifold, check valve, vacuum reserve tank, and vacuum power cylinder for possible vacuum leaks.
2. Check fluid level in hydraulic cylinder reservoir. Fluid level should be $\frac{1}{2}$ " from top of filler plug opening.
3. Check condition of air cleaner element and insert clean element if necessary.
4. Check steering column pedal plate for loose screws. Check for free operation of brake pedal. If binding exists check for misalignment between pedal and vacuum cylinder push rod.
5. Check stop light switch for proper operation.

MINOR REPAIRS

BLEEDING BRAKES

Brakes should be bled in the same manner as the standard brakes following the procedure on page 5-3.

REMOVAL OF POWER BRAKE UNIT

Remove power brake unit as outlined on page 5-19.

DISASSEMBLY OF MORaine POWER BRAKE UNIT

1. Clean all dirt from the outside of the power brake unit. Remove filler cap and gasket from master cylinder and pour brake fluid out of reservoir. (Operate push rod by hand with unit upside down to pump fluid from cylinder bore.)

2. Clamp master cylinder end of unit in vise or mount unit in special holding fixture J-5433 with adapter J-5796 (Fig. 5-39). Remove screw that holds air cleaner unit outside of power cylinder. Removal of the air cleaner unit must precede disassembly of internal parts to avoid damage to large leather piston cup inside power cylinder housing.

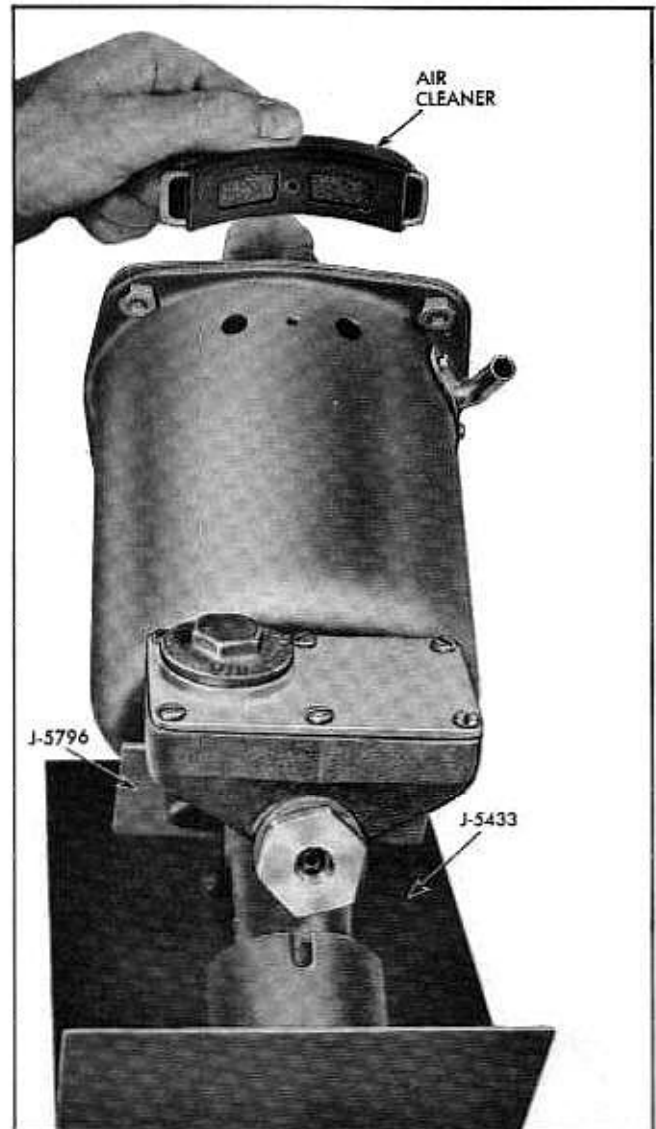

Fig. 5-39 Removing or Replacing Air Cleaner Assembly

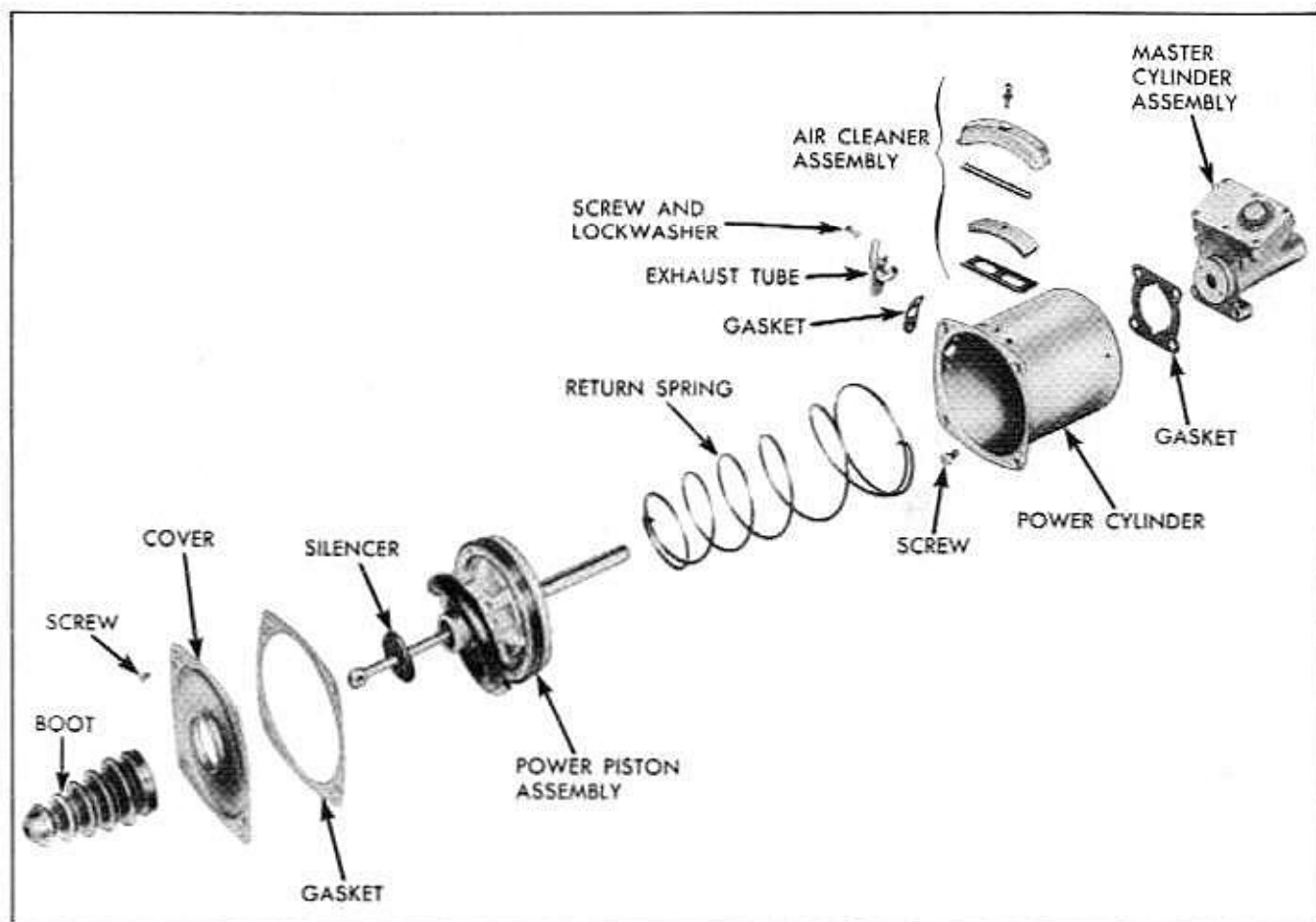

Fig. 5-40 Moraine Power Brake Unit—Exploded View

3. Remove boot and felt silencer from push rod end of power brake unit (Fig. 5-40).

4. Remove the end cover and gasket that is held to power cylinder housing by two recessed flat head screws (Fig. 5-41).

5. Slip rubber exhaust hose from vacuum exhaust tube inside the power cylinder housing (Fig. 5-42). Do not use compressed air to remove.

6. Press the power piston assembly back into the power cylinder housing so that it does not rub against the vacuum exhaust tube. Holding the power piston in this position with one hand, remove the two screws that hold the vacuum exhaust tube to the outside of power cylinder and remove tube (Fig. 5-43). Using fine emery cloth remove burrs from inside power cylinder housing at screw holes. Ease power piston out of the power cylinder housing. (There is a strong coil spring back of the power piston assembly. Be careful to control the piston by hand as it is removed from the housing.) (Fig. 5-44.)

7. Remove the large coil return spring from inside the power cylinder housing (Fig. 5-45).

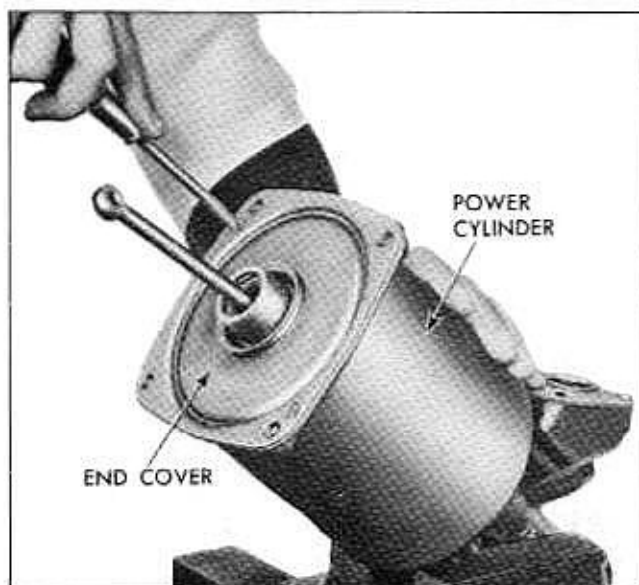

Fig. 5-41 Removing or Replacing End Cover

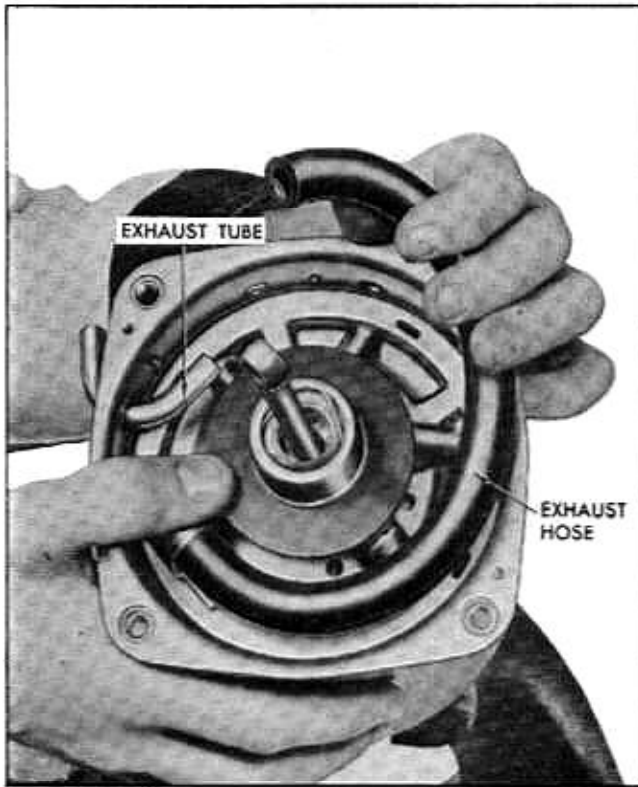

Fig. 5-42 Removing or Replacing Exhaust Hose from Intake Tube



Fig. 5-44 Removing or Replacing Power Piston Assembly

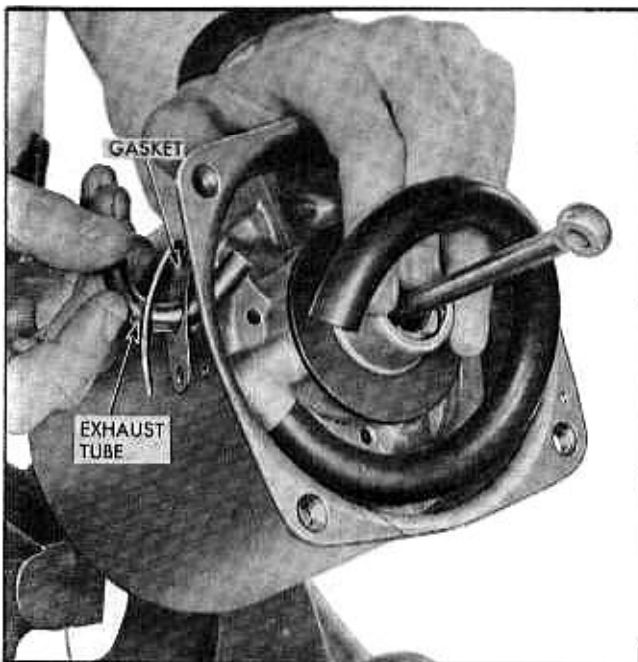

Fig. 5-43 Removing or Replacing Vacuum Intake Tube

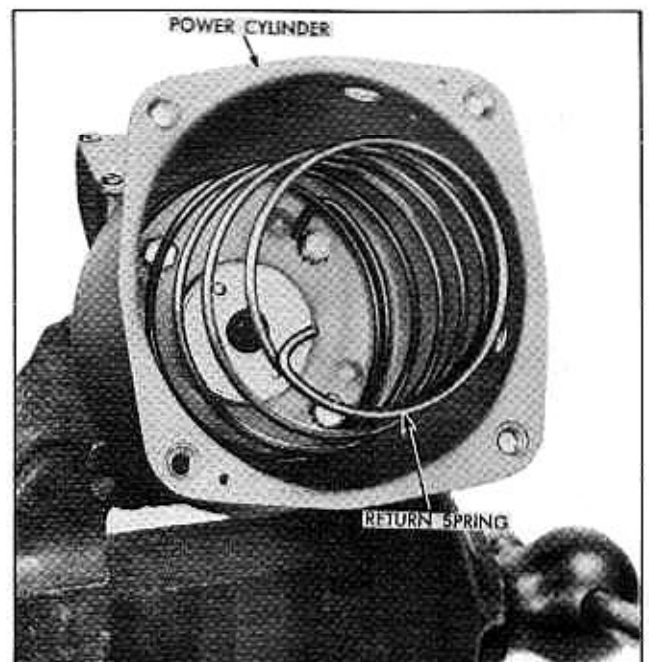

Fig. 5-45 Power Cylinder Housing and Spring Assembly

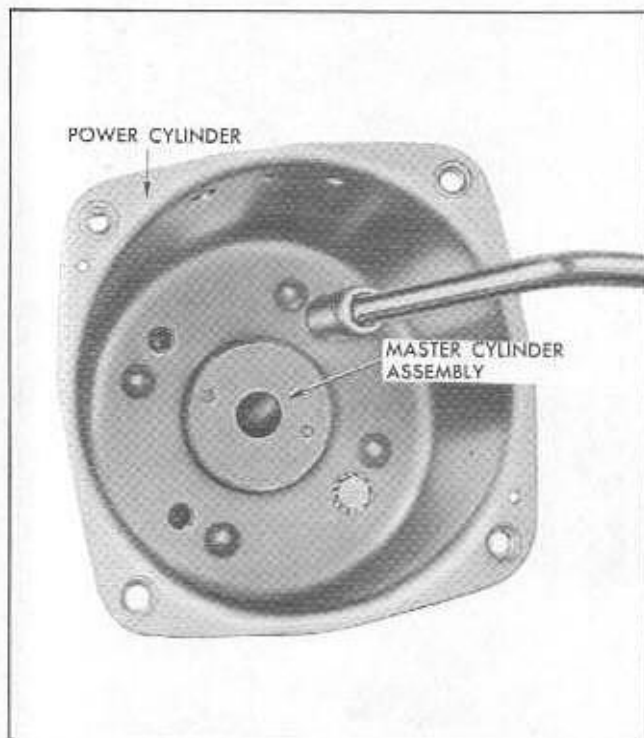

Fig. 5-46 Removing or Replacing Power Cylinder Housing

8. Remove the four hex head bolts at the inside base of the power cylinder housing that hold it to the master cylinder (Fig. 5-46). Remove the gasket between the housing and master cylinder. The power cylinder housing pilots on an extension of the cylinder plug and should be removed carefully so as not to damage the "O" ring on the plug extension.

DISASSEMBLY OF AIR CLEANER UNIT (FIG. 5-40)

1. Pull screw out through housing and assembled parts.
2. Unseat rubber gasket from edges of housing; lift out element and hairpin spring.

DISASSEMBLY OF MASTER CYLINDER

1. Clamp master cylinder in fixture J-5433 with adapter J-5796 or in a vise in vertical position and remove cylinder plug assembly using special spanner wrench J-5794 (Fig. 5-47).

2. Remove two "O" rings from outside diameter of the plug (Fig. 5-48).

3. Secondary cup, washer, retainer, and vacuum seal may now be removed from inside of plug (Fig. 5-48).

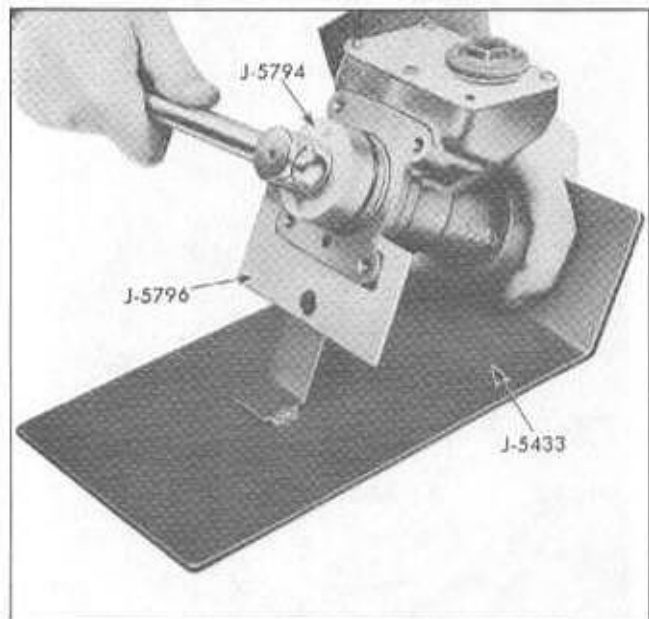

Fig. 5-47 Removing or Replacing Cylinder Plug Assembly

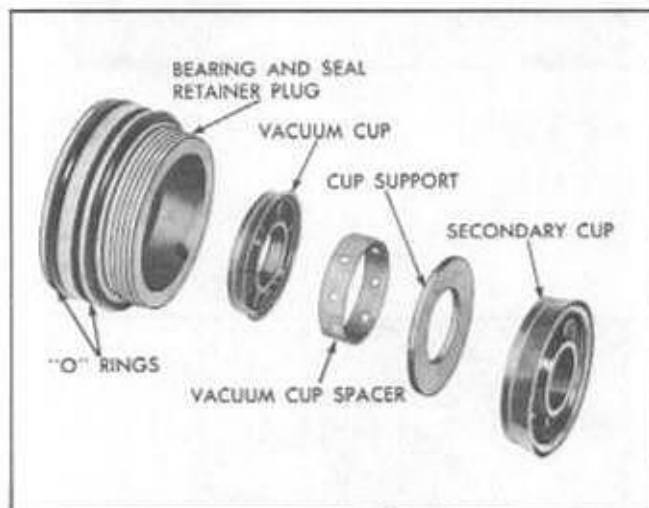
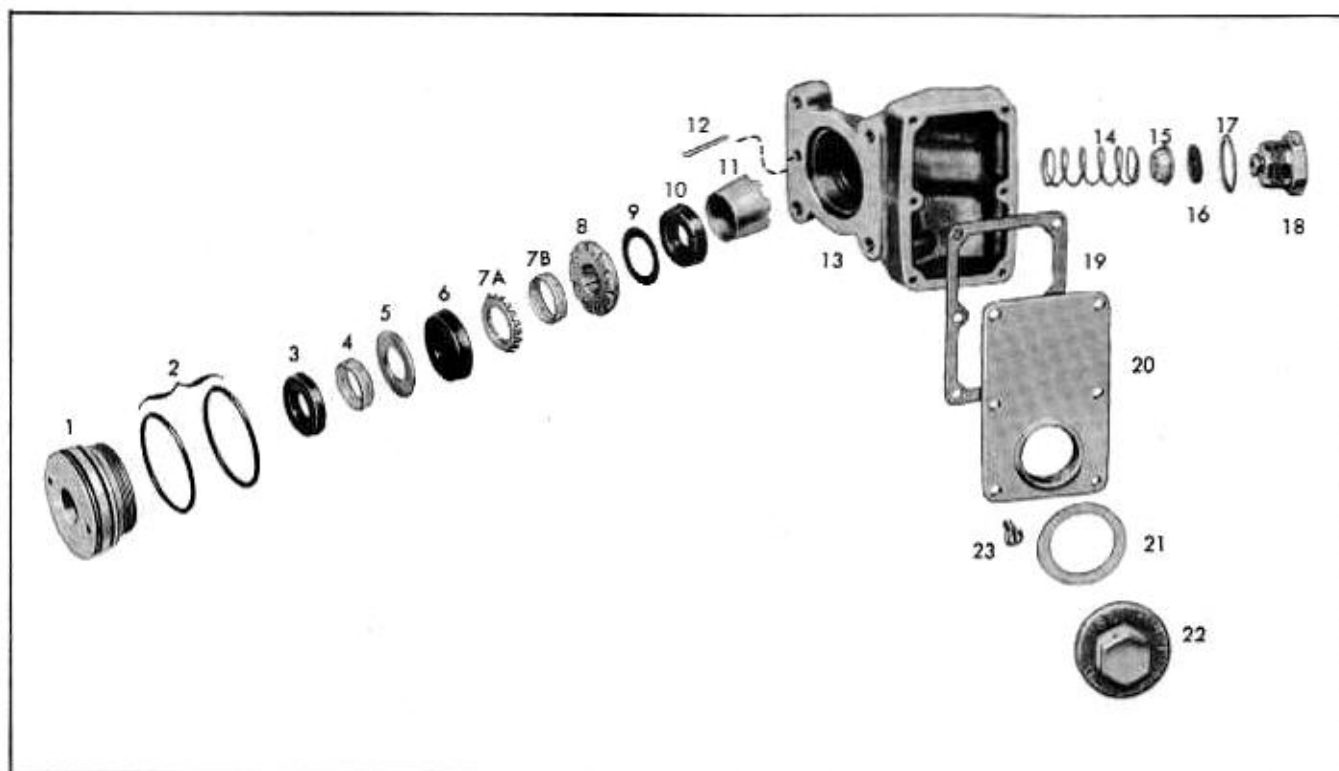

Fig. 5-48 Cylinder Plug Assembly—Exploded View

4. From the bore of the master cylinder, lift out expander, spacer, bearing, flat primary cup ring, primary cup, conical primary cup retainer (Fig. 5-49).

5. Reset in vise or tool J-5433 and remove head nut assembly and copper gasket (Fig. 5-50). (Guard against check valve and check valve spring falling from hole as head nut assembly is loosened.) Remove rubber check valve seat washer which fits over the button on the head nut.

6. Lift out check valve and check valve spring (Fig. 5-49).



- | | | |
|----------------------------------|-------------------------|------------------------------|
| 1 Bearing and Seal Retainer Plug | 8 Bearing | 16 Check Valve Washer |
| 2 "O" Rings | 9 Primary Cup Ring | 17 Head Nut Gasket |
| 3 Vacuum Cup | 10 Primary Cup | 18 Head Nut |
| 4 Vacuum Cup Spacer | 11 Primary Cup Retainer | 19 Reservoir Gasket |
| 5 Cup Support | 12 Vent Pin | 20 Reservoir Cover |
| 6 Secondary Cup | 13 Body | 21 Filler Cap Gasket |
| 7A Secondary Cup Expander | 14 Check Valve Spring | 22 Filler Cap |
| 7B Secondary Cup Spacer | 15 Check Valve | 23 Reservoir Retaining Screw |

Fig. 5-49 Master Cylinder—Exploded View

7. Inspect the fluid reservoir through the filler hole opening. If the reservoir is dirty to the extent that it cannot be thoroughly cleaned through the filler hole, remove the reservoir cover and gasket. Make note of the position of filler hole in relation to the master cylinder body. It must be replaced in the same position to permit filling with brake fluid after re-installation on the car.

8. Inspect vent on underside of casting. Vent pin (Fig. 5-49) is designed to keep this hole open. If hole is clogged and cannot be cleaned out so that the pin rides free, the pin may be straightened and removed through the counterbore end of vent hole.

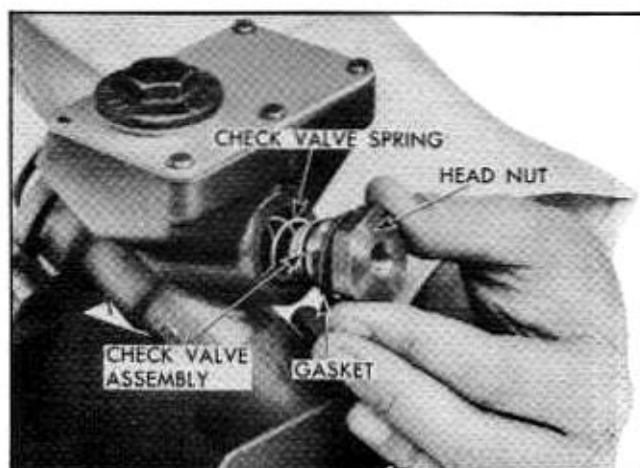

Fig. 5-50 Removing or Replacing Head Nut Assembly

DISASSEMBLY OF POWER PISTON ASSEMBLY

1. Remove vacuum hose from power piston assembly if it is to be replaced. **NOTE:** Hose is cemented to tube (Fig. 5-51).

2. Carefully unseat triangular shape lock ring with screw driver to permit removal of push rod and air valve assembly (Fig. 5-52). Exercise caution in removing the lock ring so that it will not flip out and become lost or cause personal injury. Turn power piston assembly upside down. Stop plate washer will slide out of opening in power piston and down onto push rod.



Fig. 5-51 Removing or Replacing Vacuum Hose at Power Piston

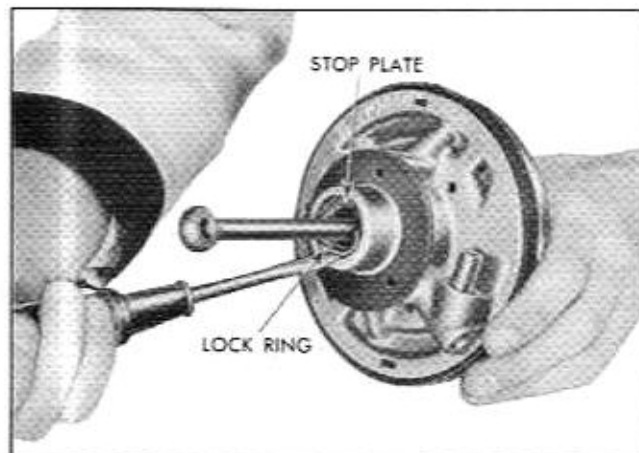

Fig. 5-52 Removing Air Valve Lock Ring

3. Carefully pull out air valve and push rod while holding piston in vertical position. Valve spring and shims will come out with the air valve (Fig. 5-53). **CAUTION:** Lift out spring and make note of number of shims which fit over valve shank and rest on valve shoulder.

4. Remove "O" ring from air valve (Fig. 5-53).

5. It is not necessary to remove the push rod from air valve unless it is noisy or excessively loose. If necessary, follow steps 5 and 6. Unseat Truarc snap ring (using special pliers J-5403) that holds push rod in place (Fig. 5-54). (Pinch snap ring to release.)

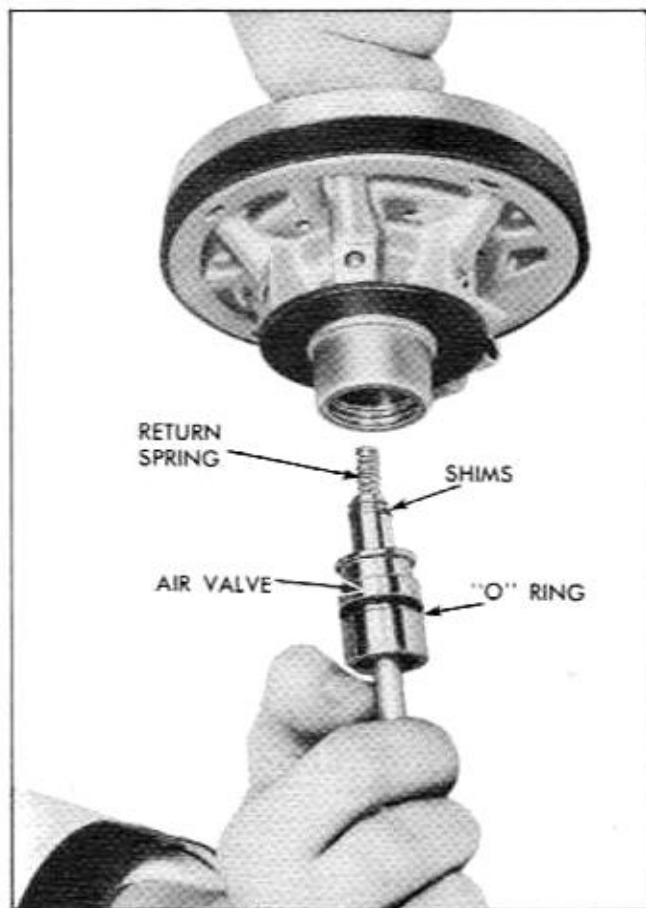

Fig. 5-53 Removing or Replacing Air Valve Assembly

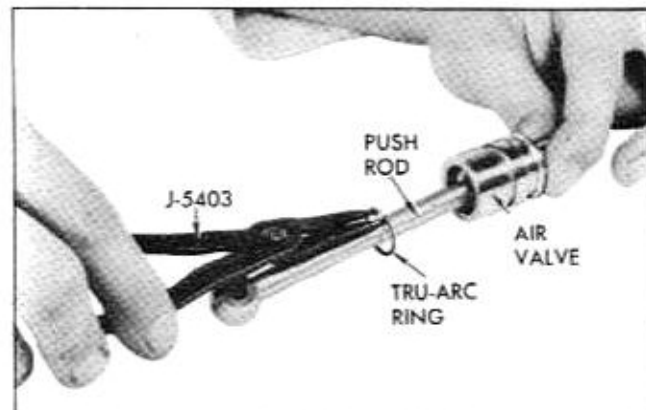

Fig. 5-54 Removing or Replacing Push Rod Snap Ring

6. Pull out push rod; remove rubber bumper from end of push rod (Fig. 5-55). (Truarc ring and washer may be left on the push rod).

7. Set power piston assembly on bench on hub end and loosen the four screws that hold the two halves of the power piston assembly together (Fig. 5-56). Before completely removing the screws press down on top half (power piston guide) with one hand. There is an internal spring between the two

halves that will have a tendency to part the two halves unless controlled by hand.

8. Gently lift off power piston guide and master cylinder piston assembly. Turn upside down and remove "O" ring from pilot on power piston guide (Fig. 5-55).

9. Slide the power piston guide off the master cylinder plunger and remove the "O" ring from the master cylinder plunger (Fig. 5-55).

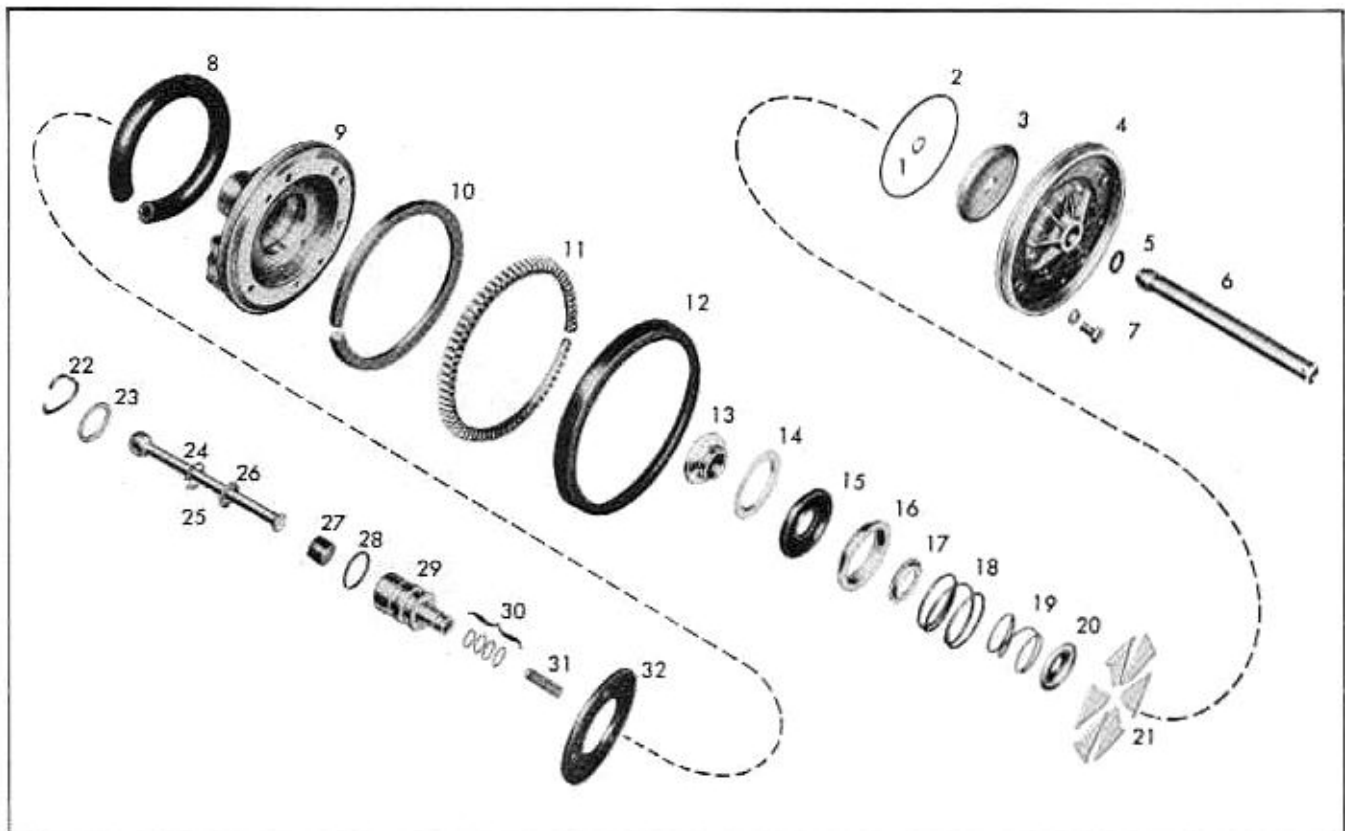

- | | | |
|---------------------------|------------------------------|------------------------|
| 1 Lock Ring | 12 Cup | 23 Stop Plate |
| 2 "O" Ring | 13 Floating Control Valve | 24 Push Rod |
| 3 Reaction Plate | 14 Diaphragm Retainer Plate | 25 Push Rod Lock Ring |
| 4 Piston Guide | 15 Valve Balancing Diaphragm | 26 Push Rod Washer |
| 5 "O" Ring | 16 Diaphragm Retainer | 27 Push Rod Bumper |
| 6 Master Cylinder Plunger | 17 Valve Spring Retainer | 28 "O" Ring |
| 7 Screw and Lockwasher | 18 Reaction Return Spring | 29 Air Valve |
| 8 Exhaust Hose | 19 Valve Diaphragm Spring | 30 Shims |
| 9 Power Piston | 20 Valve Reaction Plate | 31 Valve Return Spring |
| 10 Wick | 21 Reaction Levers | 32 Stop Bumper |
| 11 Expander | 22 Lock Ring | |

Fig. 5-55 Power Piston Assembly—Exploded View

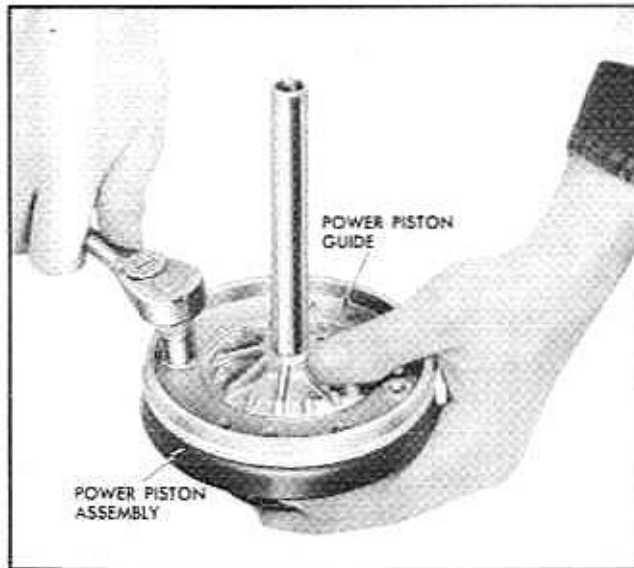

Fig. 5-56 Removing or Replacing Power Piston Guide

10. Examine the reaction plate, which is held to the end of the master cylinder piston by small Truarc ring. If it is necessary to remove the reaction plate, expand the Truarc ring with special pliers J-4880 and lift off reaction plate (Fig. 5-57).

11. From counterbore of power piston, remove in order six fingers (or reaction levers), (Fig. 5-58) reaction spring, valve plate, and valve diaphragm spring (Fig. 5-59).

12. Carefully lift large leather cup off power piston (Fig. 5-60). Keep in mind that underneath the leather cup is a metal lip expander and wick assembly that has a tendency to uncoil when released. Wick and expander may be separated for inspection.

13. Eject floating valve assembly from power piston by pulling out (Fig. 5-61), or by thumb press from hub end. If parts stick together and cannot be pressed out with the fingers, pry gently from opposite end to loosen.

14. Remove rubber power piston stop bumper from hub of power piston (Fig. 5-62).

DISASSEMBLY OF FLOATING VALVE ASSEMBLY

1. Unseat cup-shaped valve spring retainer with small screwdriver (Fig. 5-63). **CAUTION:** Use care to prevent screwdriver from damaging diaphragm.

2. Press floating control valve through inner diameter of diaphragm (Fig. 5-64). This also frees diaphragm retainer plate.

3. Unseat rubber diaphragm from groove in diaphragm retainer ring (Fig. 5-65).

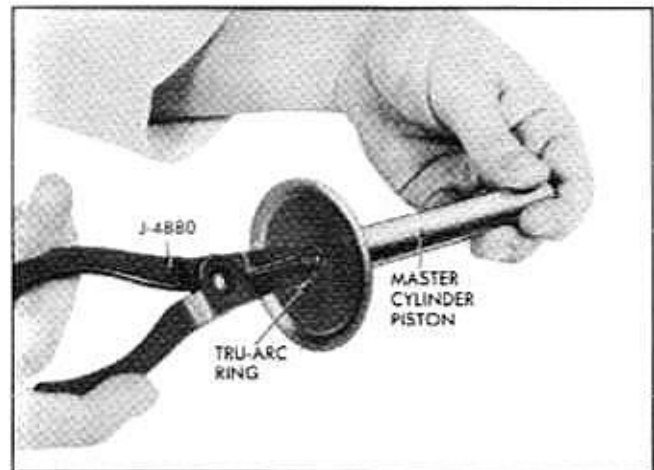

Fig. 5-57 Removing or Replacing Reaction Plate Snap Ring



Fig. 5-58 Removing or Replacing Reaction Levers

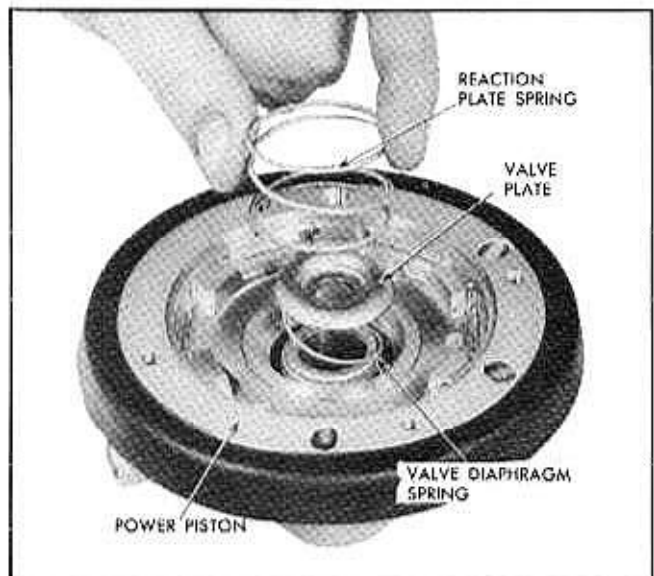

Fig. 5-59 Removing or Replacing Reaction Spring

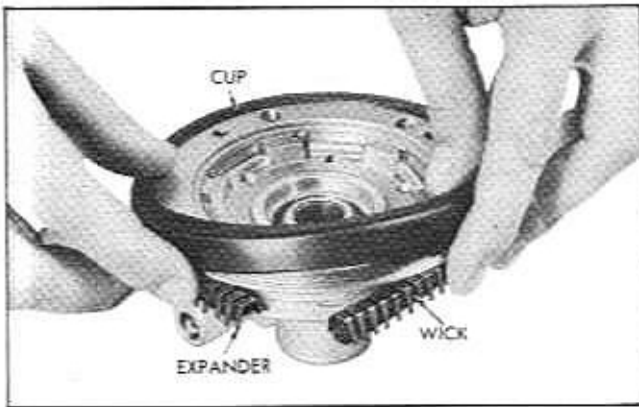

Fig. 5-60 Removing or Replacing Leather Cup

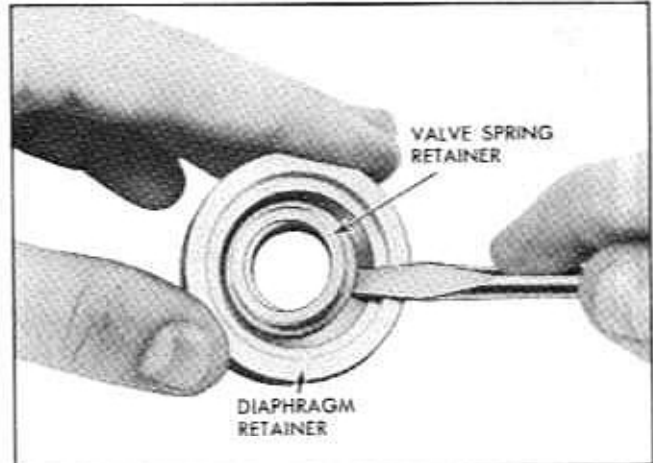

Fig. 5-63 Removing Valve Spring Retainer

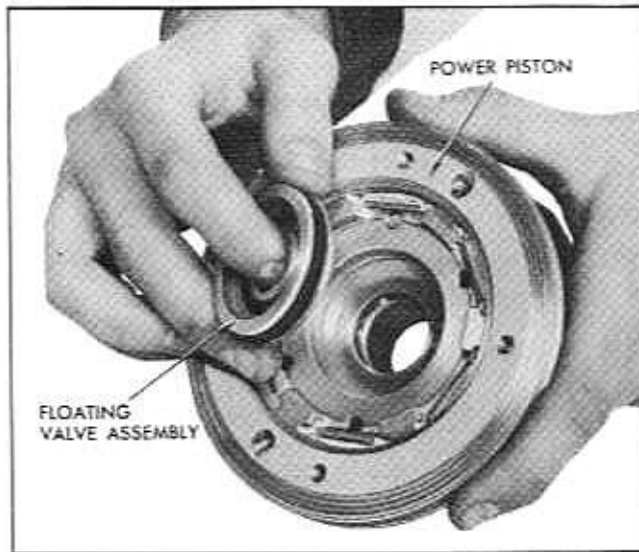

Fig. 5-61 Removing Floating Valve Assembly



Fig. 5-64 Removing Floating Control Valve

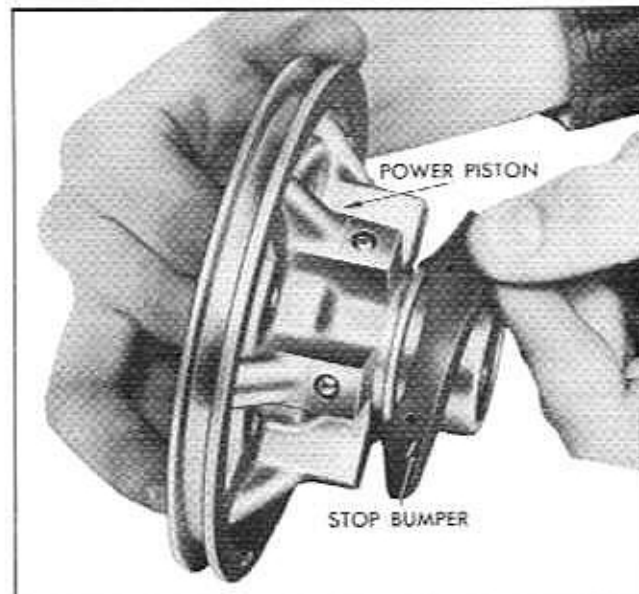

Fig. 5-62 Removing or Replacing Stop Bumper



Fig. 5-65 Removing Diaphragm

CLEANING AND INSPECTION

CLEANING

Thoroughly wash all parts in alcohol and air dry. Blow dirt and cleaning fluid out of all internal passages. If inside of vacuum cylinder is corroded or rusted, clean with crocus cloth or fine emery cloth. **CAUTION:** *It is important that all parts be placed on clean paper or cloth after being cleaned to prevent possibility of dirt being assembled into unit.*

INSPECTION

VACUUM CYLINDER HOUSING

Inspect for scoring, pitting, dents or nicks, or damaged threads. Small imperfections may be smoothed out by fine crocus cloth; replace if badly damaged.

HYDRAULIC MASTER CYLINDER CASTING

Examine bore down one inch from open end. For primary cup to seal properly, this portion of bore must be free from scores, deep scratches, and corrosion. If it appears that contaminated brake fluid has damaged the bore replace damaged parts and flush out hydraulic system.

Gasket surfaces under filler plug and head nut, and around bore should be clean and smooth. Check for cracks and damaged threads. Jiggle pin should ride free in a clean vent hole. Holes leading from bore to reservoir and outlet should be clean.

CYLINDER PLUG ASSEMBLY

Cavities should be free of imperfections to allow good seats for vacuum seal and secondary cup. Bore should be clean and smooth so it will not score the master cylinder plunger. Check outside surfaces for damaged threads and clean grooves. Be sure small radial holes are open and clean.

HEAD NUT ASSEMBLY

Check for damaged threads and smooth seat. Use new check valve seat washer and head nut gasket if necessary when reassembling.

CHECK VALVE AND SPRING

Check for distortion and deterioration of rubber.

FILLER CAP ASSEMBLY

Check for damaged threads or badly worn gasket. Be sure two breather holes are clean and open.

COVER PLATE

Examine plate and screws for imperfections. Use new gasket if needed.

MASTER CYLINDER PLUNGER

Examine carefully for nicks, corrosion, and abrasion. Radial holes in counterbore should be open. If scored, pitted, or distorted, replace with new plunger.

MASTER CYLINDER PLUNGER BEARING

Grooves and holes must be clean. Check fit of master cylinder plunger in bearing hole. If badly worn or damaged, replace.

VACUUM INLET TUBE

Make sure braze is secure and tube plate is not distorted.

AIR FILTER ASSEMBLY

Replace element if filled with dirt or damaged. Replace rubber gasket if cracked or torn.

AIR VALVE

Check for scratches, dents, distortion, or corrosion on both outside and inside surfaces. Check seat for smoothness and flatness. Should have free sliding fit when inserted in power piston bore.

FLOATING VALVE ASSEMBLY

Check for distortion of metal parts and deterioration or abrasions of rubber parts.

POWER PISTON AND GUIDE

Check for cracks, damaged threads, pitted or rough holes, distortion, damage to lever seats, chipping, and rough or uneven seat for floating valve. Be sure all openings and passageways are open and clean.

POWER CYLINDER HOUSING COVER

Examine for distortion.

SEALS, SPRINGS, CUPS, "O" RINGS, ETC.

Very carefully examine all rubber, leather and other perishable parts and replace if they are damaged or worn. Check all springs for distortion and loss of tension. Replace where necessary. Check levers and reaction plates for scuffing or distortion.

REPAIR OF POWER BRAKE UNIT

The bores of the master cylinder and vacuum cylinder may be cleaned and reconditioned with fine crocus cloth if not too deeply pitted or scratched. The six levers may be flattened by tapping with a wooden mallet if they are not badly distorted. All other internal working parts must be replaced if damaged.

ASSEMBLY OF MORaine POWER BRAKE UNIT

MASTER CYLINDER ASSEMBLY

1. Drop check valve spring into place in 1" threaded opening in master cylinder casting. Seat check valve assembly into the check valve spring. Button check valve seat washer onto headnut, and fit copper headnut gasket over threaded end of headnut. Screw headnut in place carefully to avoid binding the check valve as it is depressed into the hole in the casting (Fig. 5-50). A few drops of brake fluid on the check valve seat washer will facilitate assembly. (Torque 85-100 ft. lbs.).

2. Replace reservoir gasket and cover. Install all screws. Be sure reservoir cover is installed with filler hole in proper position (Fig. 5-49). Use new gasket if necessary. Install filler cap and gasket loosely to avoid danger of dirt entering reservoir during assembly of power brake unit.

3. Clamp master cylinder in fixture or vise in vertical position with large counterbore facing upward. Wipe counterbore and threads with very thin coating of brake fluid. Place conical primary cup retainer with notched end down into open end of bore; press primary cup into hole (note that the outer lip of primary cup fits around and over the small end of the retainer when it is properly centered in the hole). Place primary cup retainer (thin blued steel washer) in place on back of primary cup. Set bearing into bore with notched side up, making sure that the hub of the bearing fits into the counterbore on the back of the primary cup. Place spacer on top of bearing (Fig. 5-49) and place expander on top of spacer with fingers toward bearing.

4. Assemble cylinder plug assembly as follows: Seat vacuum cup seal with ribbed sides up into

bottom of the counterbore of the cylinder plug; place spacer on top of vacuum cup (this spacer is smaller in diameter than the secondary cup spacer); follow with secondary cup washer; seat secondary cup with ribbed side up in large counterbore; slip $1\frac{51}{64}$ " "O" ring into first groove on O.D. (nearest the end of plug opposite threaded section); slip second $1\frac{51}{64}$ " "O" ring over threaded end and seat on hub which has same diameter as first groove (Fig. 5-48). CAUTION: No "O" ring should be placed in second groove that has four small through holes.

5. Screw cylinder plug assembly into place (Fig. 5-47). CAUTION: Spacer and expander must be centered properly on top of bearing so that lips of secondary cup fit around expander when plug is screwed into place. Use special spanner wrench J-5794 for tightening cylinder plug assembly (20-30 lb. ft. torque).

6. If necessary, replace jiggle pin (Fig. 5-49) in vent hole and bend to approximately 45° to hold in place. Head of pin rides in counterbore of hole.

7. Assemble power cylinder housing to master cylinder with four $\frac{5}{16}$ " hex head screw and lock-washer assemblies (12-14 lb. ft. torque) (Fig. 5-46). Be sure to install gasket between housing and master cylinder and position notch in gasket over vent hole in cylinder. The housing pilots on the extended portion of cylinder plug assembly. Assembly is facilitated by wiping the bore of housing pilot hole with thin coat of Hydra-Matic fluid. In assembling the housing be sure that two $\frac{3}{8}$ " air intake holes are on top (match reservoir cover side of master cylinder). Exercise care in installing housing so as not to damage "O" ring on cylinder plug extension.

POWER PISTON ASSEMBLY

1. Assemble floating valve assembly as follows: Fit rubber diaphragm over small diameter of diaphragm retainer ring. Hold diaphragm retainer plate on back of diaphragm with one hand, flat side of plate adjacent to rubber; press floating control valve into place over retainer plate (Fig. 5-55). The hub end of the valve fits through the hole in the rubber diaphragm. Press cup shaped valve spring retainer over hub of floating valve and inner flange of diaphragm. Wipe outside diameter of floating valve assembly lightly with Hydra-Matic fluid.

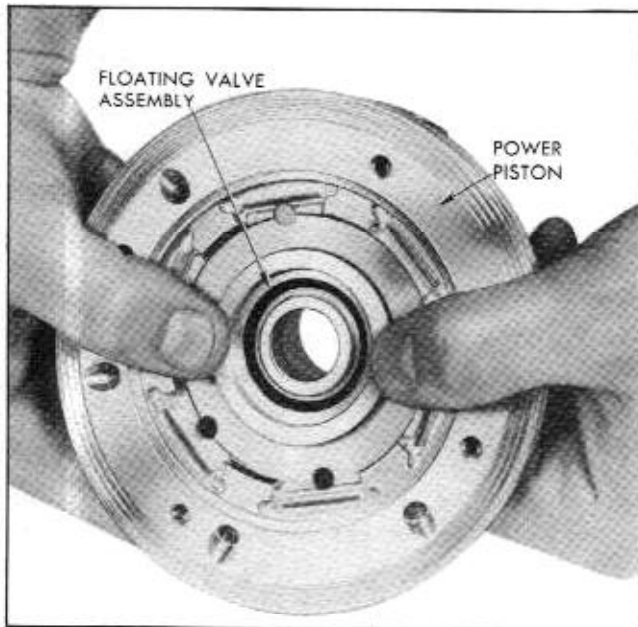

Fig. 5-66 Replacing Floating Control Valve

2. Set power piston casting on bench, hub end down. Press by hand the floating valve assembly, with rubber valve face down, into power piston counterbore (Fig. 5-66).

3. Assemble felt wick in channel of metal lip expander. If new wick is used, soak in Hydra-Matic fluid allowing excess to run off.

4. Install wick and expander assembly into outer groove of piston with expander fingers on outside and pointing toward hub end of power piston.

5. Holding expander in place, slip leather cup in place with lip also pointing toward hub end of piston (Fig. 5-60). If new leather cup is installed use cardboard cylindrical retainer to confine cup during installation. This will avoid any sluggishness in operation during first few days of use or until leather becomes softened by fluid.

6. Snap valve diaphragm spring in place over valve spring retainer (Fig. 5-59).

7. Seat valve plate on top of valve diaphragm spring so that center portion nests in spring (Fig. 5-59).

8. Place reaction spring around valve diaphragm spring and seat in recess of valve diaphragm retainer (Fig. 5-59).

9. Set six reaction levers in place. Ears on levers fit into mating slots in face of power piston. Small ends of levers will extend toward the middle and rest on reaction spring (Fig. 5-58).

PISTON GUIDE ASSEMBLY

1. Place $\frac{5}{8}$ " "O" ring in groove of master cylinder plunger (Fig. 5-55).

2. Place reaction plate over small end of piston with raised edge extending outward (Fig. 5-57).

3. Retain reaction plate on plunger with Truarc snap ring using special pliers J-4880 (Fig. 5-57).

4. Lubricate lightly "O" ring and adjacent surface of master cylinder plunger with Dow Corning Valve Seal "A" or equivalent silicone grease.

5. Fit $3\frac{1}{2}$ " "O" ring onto machined hub of piston guide. (Fig. 5-55).

POWER PISTON AND PISTON GUIDE ASSEMBLY

1. Holding master cylinder plunger assembly in one hand in vertical position with reaction plate down, start piston guide (ribbed side up) over upper end of plunger. Gently seat master cylinder plunger and reaction plate assembly onto reaction levers. Press down quickly and firmly until the six reaction levers are held in flat position. Be sure each lever is properly seated. Place hand on top of master cylinder plunger to hold in place (Fig. 5-67). Gently slide piston guide into place indexing holes to match those in piston

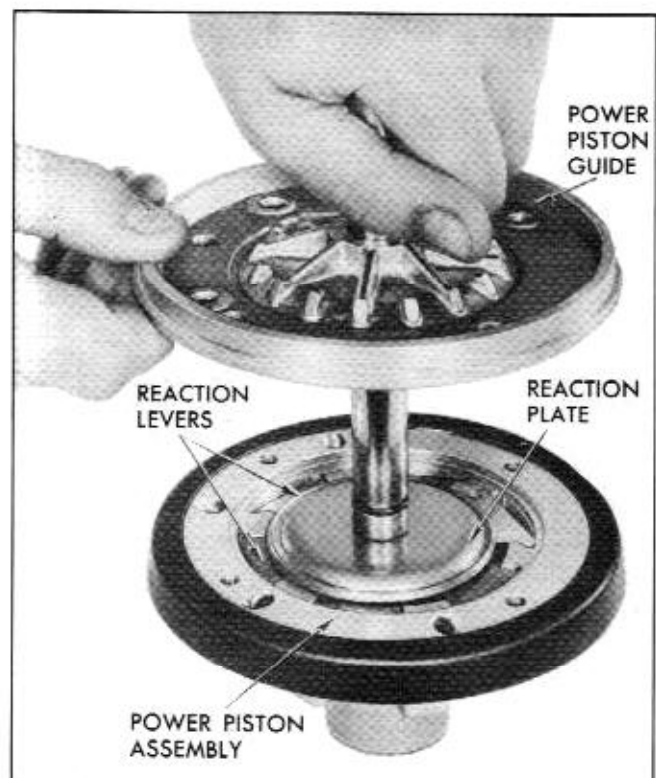

Fig. 5-67 Replacing Piston Guide to Power Piston Assembly

casting. Install 4 hex head $\frac{3}{4}$ " screws and lock-washers to complete assembly (5-7 lb. ft. torque) (Fig. 5-56). To assure that reaction levers are properly seated, check to see that master cylinder piston has slight movement in power piston assembly.

2. Turn the assembled unit over and install rubber bumper in groove on hub of power piston (Fig. 5-62).

AIR VALVE AND PUSH ROD ASSEMBLY

1. Assemble rubber bumper onto end of push rod.
2. Insert bumper and push rod assembly into air valve (Fig. 5-55).
3. Allow metal washer on push rod to seat on back of rubber push rod bumper.
4. Using special pliers J-5403, snap Truarc ring into groove in air valve (Fig. 5-54). Check carefully to make sure that the push rod is firmly locked into the air valve.

5. Assemble 1" "O" ring in the narrow groove on the outside of the air valve. Coat "O" ring and outside diameter of air valve with light coat of Dow Corning Valve Seal "A" or equivalent silicone grease (Fig. 5-55).

6. Place same number shims that were on air valve, on Tool J-5805. Invert power piston and insert gauge into bore of power piston (Fig. 5-68). Shims and body of gauge will rest on valve plate and pin will extend through hole in valve and rest on end of master cylinder plunger. Turn power piston over so gauge is on top (Fig. 5-68) and check position of pin in gauge body. Pin should be flush or slightly above gauge body. Remove or add shims until pin is flush or slightly above gauge body. Removing of shims will raise pin in gauge body and adding shims will lower pin in gauge body.

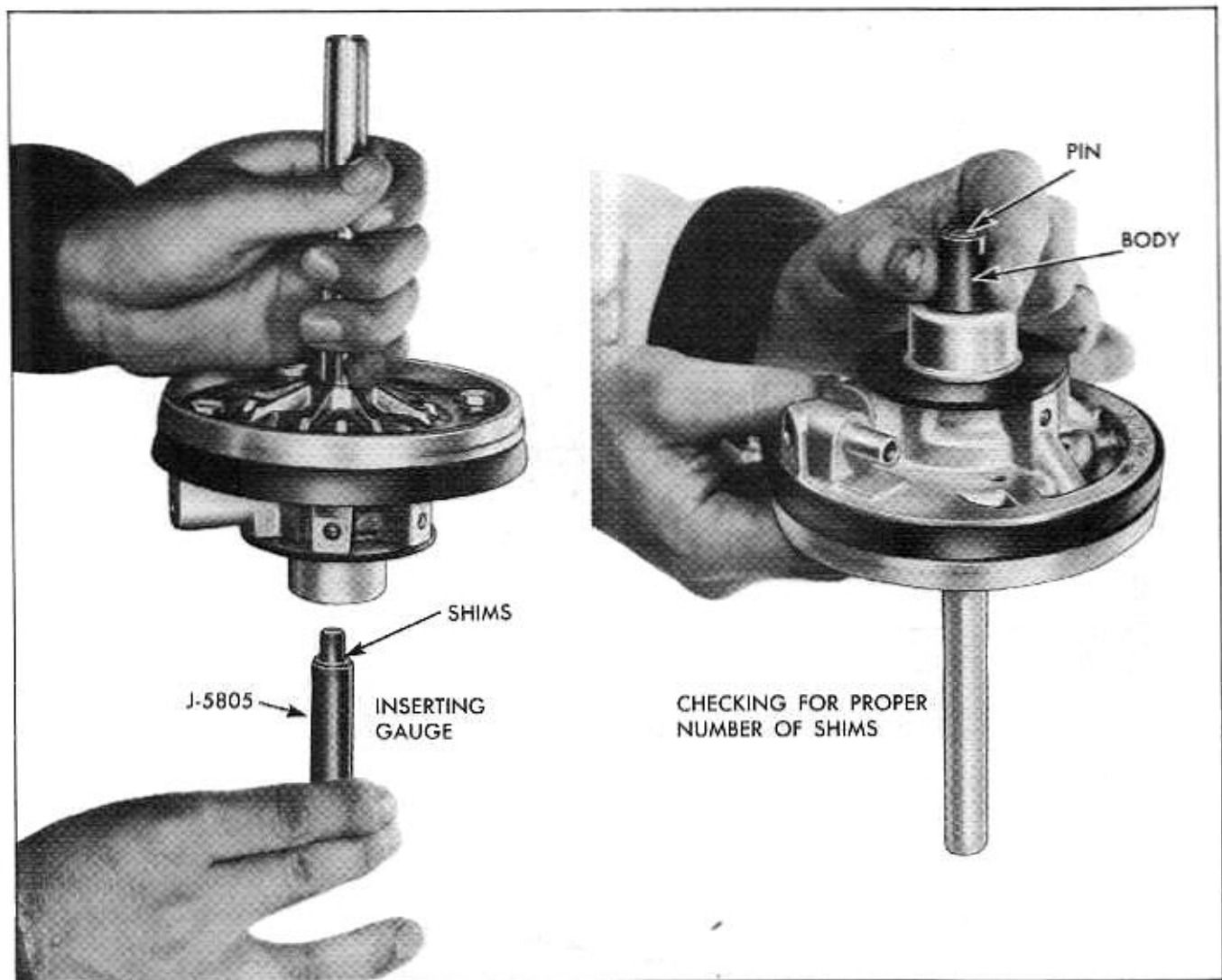

Fig. 5-68 Air Valve Shim Check

7. After proper number of shims has been added to small diameter of air valve, insert valve return spring into small hole in air valve.

8. Holding the power piston and guide assembly with master cylinder plunger pointing upward, insert from below the air valve, spring, and push rod assembly into the hub end of the power piston (Fig. 5-53). **CAUTION:** Assemble in this manner to avoid dislodging shims and valve return spring.

9. Carefully turn power piston, guide, air valve and push rod assembly over and insert stop plate and triangular lock ring which hold the air valve in place. Lock ring may be assembled by using small screwdriver (Fig. 5-69). After being locked in place, the air valve will have approximately $\frac{1}{32}$ " travel against valve return spring before picking up floating valve load. *Care should be exercised during this operation to avoid damage to the master cylinder plunger. Never put the master cylinder plunger into a vise.*

ASSEMBLY OF POWER PISTON AND GUIDE ASSEMBLY IN POWER CYLINDER HOUSING

1. Lubricate lightly the large bore of the power cylinder housing with Hydra-Matic fluid.

2. Clamp the master cylinder in vise or tool J-5433 in a vertical position with the opening in the housing extending upward. Place large coil return spring into

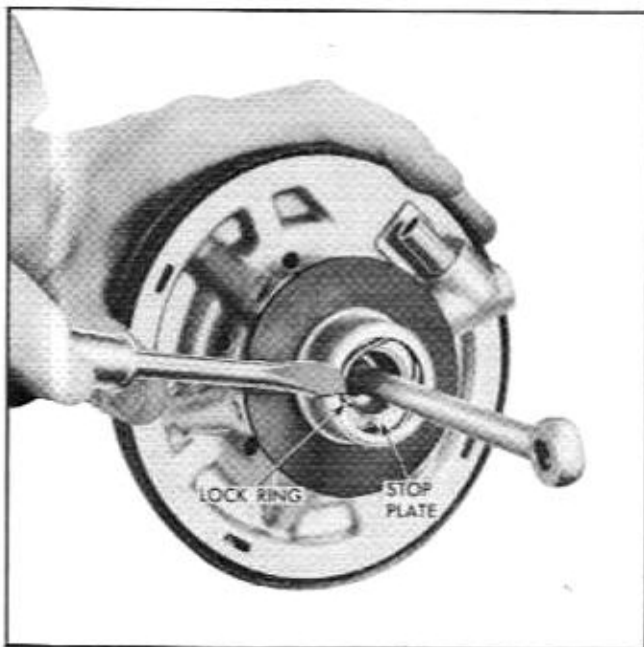

Fig. 5-69 Replacing Air Valve Lock Ring

housing with large diameter in bottom of housing. The tang on the bottom of the spring should be placed in narrow space between any one of the hex bolt heads and closest locating extrusion or dimple (Fig. 5-45).

3. Wipe lip of leather cup with light coating of Hydra-Matic fluid to clean and lubricate.

4. If rubber exhaust hose has been removed from power piston for replacement, coat exhaust tube with 3M Super Weatherstrip cement and slip new hose on tube as far as it will go (Fig. 5-51).

5. Place power piston and assembled parts on top of coil spring so that the boss plugged with the largest ball will enter housing below the exhaust tube hole in housing by approximately $\frac{1}{4}$ ". Press power piston assembly into housing (Fig. 5-70).



Fig. 5-70 Positioning Power Piston Assembly

6. Depress power piston assembly into housing against the coil spring load. This permits assembly of exhaust tube and gasket to outside of housing. Install tube in proper direction so that the inside connection will assemble correctly with rubber exhaust hose (Fig. 5-43). (Two fillister head 8-32 screws.)

7. Slip rubber exhaust hose onto metal exhaust tube inside housing (Fig. 5-42), (approximately $\frac{1}{2}$ ") and cement hose to exhaust tube.

8. Permit power piston to ease back against exhaust tube connection.

9. Install power cylinder housing cover and gasket using 2 flat head 8-32 screws (Fig. 5-41). Press the cover down by hand in order to start the screws into the housing.

10. Slip felt silencer and boot over push rod. Seat felt silencer against hub of power piston and fit boot snugly over flange on housing cover (Fig. 5-40).

AIR CLEANER ASSEMBLY (FIG. 5-40)

1. Lay hairpin spring inside air cleaner cover.
2. Lay filter element on top of hairpin spring.
3. Place rubber gasket on filter element, depress spring and element so that the edges of the gasket can be fitted over the flanges of the air cleaner housing.
4. Insert cover screw (10-32) with gasket in place through assembled unit and screw into top housing. **CAUTION:** Air cleaner assembly must not be assembled to housing prior to this time, otherwise there is danger of damaging the leather piston cup, because the air cleaner cover screw extends through to the inside of the housing.

INSTALLATION OF MORAINÉ POWER BRAKE UNIT

Install unit as outlined on page 5-26.

DIAGNOSIS AND TESTING— MORAINÉ POWER BRAKES

SYSTEM TESTS

Road test brakes by making a brake application at about 20 MPH to determine if vehicle stops evenly and quickly. If pedal has a spongy feel when applying the brakes, air may be present in the hydraulic system. Bleed system as described on page 5-5.

When engine is stopped and transmission is in neutral, apply brakes several times to deplete all vacuum reserve in the system. Depress brake pedal, hold light foot pressure on pedal and start engine. If the vacuum system is operating, pedal will tend to fall away under foot pressure, and less pressure will be required to hold pedal in applied position. If no action is felt, vacuum system is not functioning.

Stop engine and again deplete all vacuum reserve in system. Depress brake pedal and hold foot pressure on pedal. If pedal gradually falls away under foot pressure, the hydraulic system is leaking.

If the brake pedal travels to within 1" of the toe-board, brake shoes require adjustment or relining.

TROUBLE DIAGNOSIS

The same types of brake troubles are encountered with power brakes as with standard brakes. Before checking power brake system for source of trouble refer to trouble diagnosis of standard brakes on page 5-8. After these possible causes have been eliminated check for cause as outlined below.

HARD PEDAL

- a. Vacuum Failure due to
 1. Faulty vacuum check valve.
 2. Collapsed vacuum hose.
 3. Plugged vacuum fittings, hose or pipes.
 4. Leak between vacuum power cylinder and hydraulic master cylinder.
- b. Bound up pedal mechanism.
- c. Power Brake unit trouble.
 1. Internal vacuum hose loose or restricted.
 2. Jammed sliding valve.
 3. Vacuum leaks in unit caused by loose piston plate screws, loose piston packing, faulty master cylinder piston, vacuum seal, or between Hydraulic Master Cylinder and Vacuum Power Cylinder.
 4. Defective diaphragm.
 5. Restricted air cleaner.

GRABBY OR HUNTING BRAKES (APPARENT OFF-AND-ON CONDITION)

- a. Power Brake unit valve trouble.
 1. Reaction diaphragm leakage, faulty rubber bumper pad in reaction diaphragm.
 2. Sticking sliding valve reaction.
 3. Restricted diaphragm passage.
 4. Master cylinder plunger binding in power piston guide.
 5. Improper number of shims on air valve.

PEDAL GOES TO FLOOR (OR ALMOST TO FLOOR)

- a. Brake adjustment.
- b. Fluid reservoir needs replenishing.
- c. Power brake hydraulic leakage.
 1. Defective primary or secondary cup.
 2. Defective vacuum seal.
 3. Defective head nut or head nut gasket.
 4. Cracked master cylinder casting.
 5. Leaks at wheel cylinder or in pipes, or in connections.
 6. Defective "O" rings on cylinder plug.

- d. Faulty master cylinder check valve that has permitted air to enter system causing spongy pedal.

TORQUE SPECIFICATIONS POWER BRAKE UNIT (MORAINE)

	Lb. Ft.
Master Cylinder Head Nut	85-100
Cylinder Plug to Master Cylinder	20-30
Power Cylinder Housing to Master Cylinder Screws	12-14
Piston Guide to Piston Casting Screws	5-7

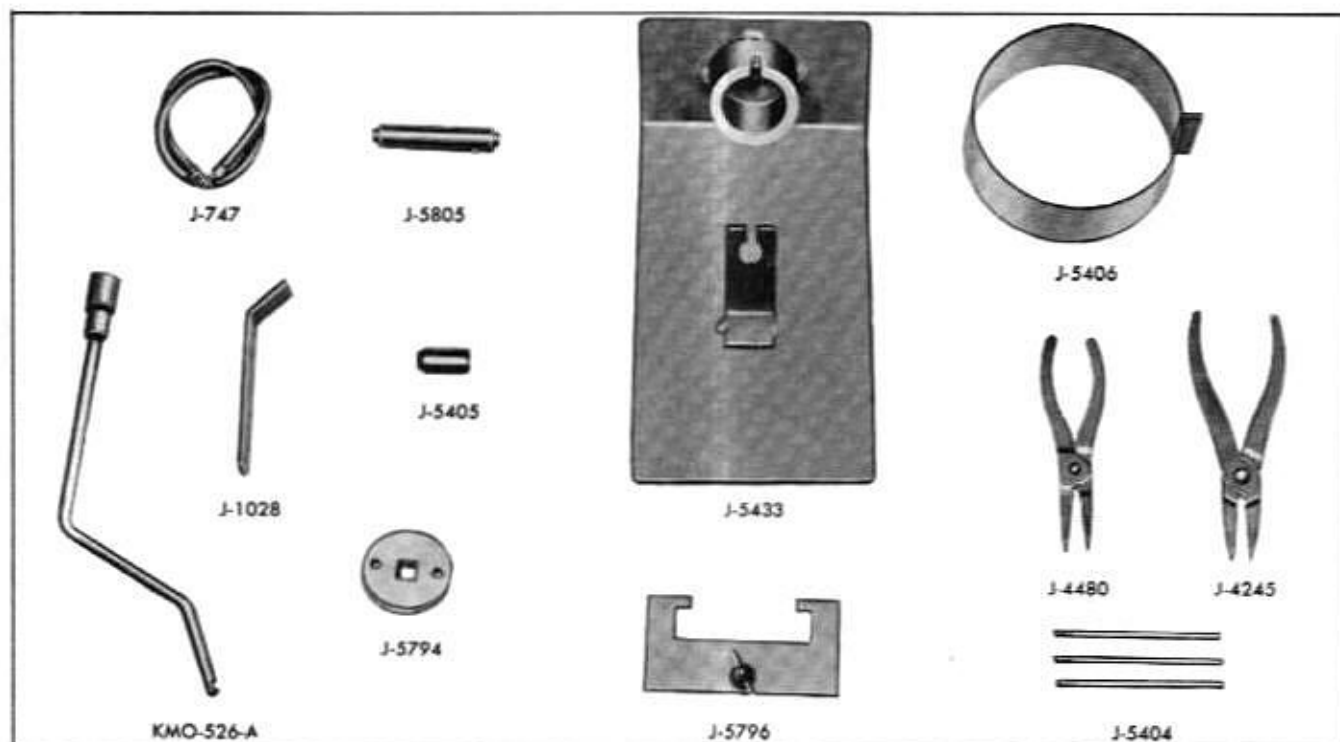

SPECIAL TOOLS—BRAKES

J-747	Brake Bleeder Tube
J-1028	Brake Adjusting Wrench
J-4245	Snap Ring Pliers
J-4880	Snap Ring Pliers
J-5404	Power Brake Guide Pin Set (3)
J-5405	Power Brake Seal Installer
J-5406	Power Brake Piston Assembly Ring
J-5433	Power Brake Cylinder Holding Fixture
J-5794	Power Brake Master Cylinder Nut Remover & Replacer
J-5796	Power Brake Holding Fixture Adapter
J-5805	Power Brake Air Valve Piston Shim Gauge
KMO-526-A	Brake Spring Remover and Replacer Wrench