

Fig. 7-1 Cross Section of Transmission

TRANSMISSION AND GEARSHIFT CONTROL

CONTENTS OF THIS SECTION

SUBJECT	PAGE	SUBJECT	PAGE
General Description	7-1	Removal of Transmission	7-5
Periodic Service	7-2	Disassembly of Transmission	7-6
Gearshift Lever—Adjust	7-2	Repairs	7-11
Rear Bearing Retainer		Assembly of Transmission	7-12
Oil Seal—Replace	7-2	Transmission Installation	7-13
Steering Column Shift Linkage		Trouble Diagnosis	7-14
Remove	7-3	Specifications	7-15
Replace	7-4	Special Tools	7-16

GENERAL DESCRIPTION

TRANSMISSION

Features of the transmission (Fig. 7-1) include the use of helical gears, ball and roller type bearings on the main shaft, needle roller bearings on the counter-shaft and a synchronizing unit.

The front universal joint yoke is supported on a steel back babbitt bushing in the transmission rear bearing retainer. The rear oil seal consists of a spring loaded leather seal and a felt seal. This seal is protected by an outer and inner shield.

The synchronizing mechanism (Figs. 7-1 and 7-26) consists of two bronze cone type synchronizing drums machined to match the conical surfaces on gears. A second and third speed clutch has internal teeth which engage the splines of the main shaft and external splines which can engage internal teeth of second speed gear or clutch gear. Spacing pins are placed through openings of the flange and pressed into holes in the synchronizing drums. Detent springs engage sides of grooves in the spacing pins which must be depressed before the second and third speed clutch can be moved past engagement of the synchronizing drums with second speed gear in clutch gear. These springs provide the clutching friction which synchronizes the second and third speed gear.

POWER FLOW

In neutral, two gears are directly connected (splined) to main shaft, the synchronizer clutch, and first and reverse sliding gear. The first and reverse sliding gear is positioned so that it does not mesh with the counter gear or the reverse idler gear. The synchronizer clutch is positioned so that it does not engage

with the second speed gear or the main drive gear. Therefore, the main drive gear, counter gear, and reverse idler gear are turning with engine clutch engaged without power being transmitted through the transmission.

In first speed, the first and reverse sliding gear is moved forward to mesh with the counter gear. The main drive gear turns the counter gear, which turns the first and reverse sliding gear that is splined to the main shaft, thus transmitting power.

In second speed, the first and reverse sliding gear is moved to a neutral position. The synchronizer clutch which is splined to the main shaft is moved toward the rear of the transmission engaging the second speed gear which floats on a bronze bushing on the main shaft. The main drive gear and the second speed gear are always in constant mesh with the counter gear. Therefore the main shaft is turning transmitting power through the transmission.

In third speed, the synchronizer clutch is moved forward away from the second speed gear into mesh with main drive gear. The synchronizer clutch is splined to the main shaft and rotation is in direction of engine rotation at engine speed.

In reverse speed, the synchronizer clutch is in neutral position, and the first and reverse sliding gear is moved to engage with reverse idler gear. The power flow in reverse gear is from the main drive gear through counter gear, reverse idler gear, first and reverse sliding gear to main shaft. The reverse idler gear changes the direction of rotation of the first and reverse sliding gear, therefore, direction is opposite to engine rotation.

TRANSMISSION SHIFT CONTROL (FIG. 7-2)

The steering column shift linkage is known as the concentric tube type. The upper gearshift lever engages a concentric tube inside the steering column. Movement of the gearshift lever rotates the tube or slides it up and down inside the steering column. A lower gearshift lever, bolted to the lower end of the tube, moves the transmission gearshift control rod when the upper gearshift lever is moved parallel with the steering wheel. The selector lever at the lower end of the steering column is actuated by a pin which rides in the selector collar near the lower end of the concentric tube. By this means, movement of the shift lever in a direction perpendicular to the steering wheel is transmitted to the transmission gearshift selector rod.

A return spring below the gearshift tube selector collar provides force to return the tube to the upward position. Thus the shift lever will always return to the high speed side as soon as it is moved to the neutral position.

Felt insulator pads inside the steering column prevent the transmission of engine and road noise up the steering column.

The shift linkage for Hydra-Matic is essentially the same in appearance and operation except selector parts are omitted.

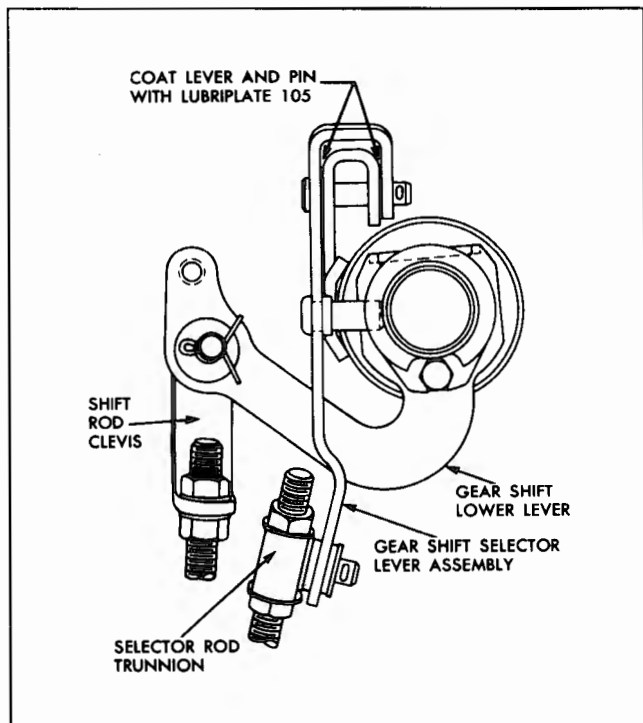

Fig. 7-2 Lower Steering Column Details

PERIODIC SERVICE**TRANSMISSION**

No periodic service of the transmission is required except checking for leaks and proper lubricant level at each 2000 mile chassis lubrication (for details see General Lubrication Section).

TRANSMISSION SHIFT CONTROL

No periodic service of the shift control is required. Certain parts are lubricated on assembly as outlined under "Installation of Steering Column Shift Linkage".

GEARSHIFT LEVER—ADJUST

Proper gearshift lever position is obtained by means of the clevis and trunnion which connect the gearshift control rod and selector rod respectively to levers at lower end of steering column (Fig. 7-2).

1. When gearshift lever is in neutral position, clearance between lever and steering wheel should be approximately 3" (Fig. 7-3). To adjust, hold transmission selector rod in its rearmost position, (normal position for 2nd and 3rd) and adjust selector rod trunnion for proper gearshift lever position. Lengthen selector rod to move lever closer to steering wheel.

2. Neutral position of gearshift lever should be approximately 13° above horizontal. To raise or lower gearshift lever, adjust length of gearshift control rod by adjusting clevis. (Lengthen control rod to raise upper gearshift lever).

**REAR BEARING RETAINER
OIL SEAL—REPLACE**

1. Disconnect rear universal joint. Use tape or a rubber band to prevent trunnion bearings from slipping off universal joint spider if retainer strap has been removed.

2. Remove propeller shaft by sliding it to rear off transmission mainshaft spline.

3. Remove shield from rear bearing retainer.

4. Remove oil seal from rear bearing retainer.

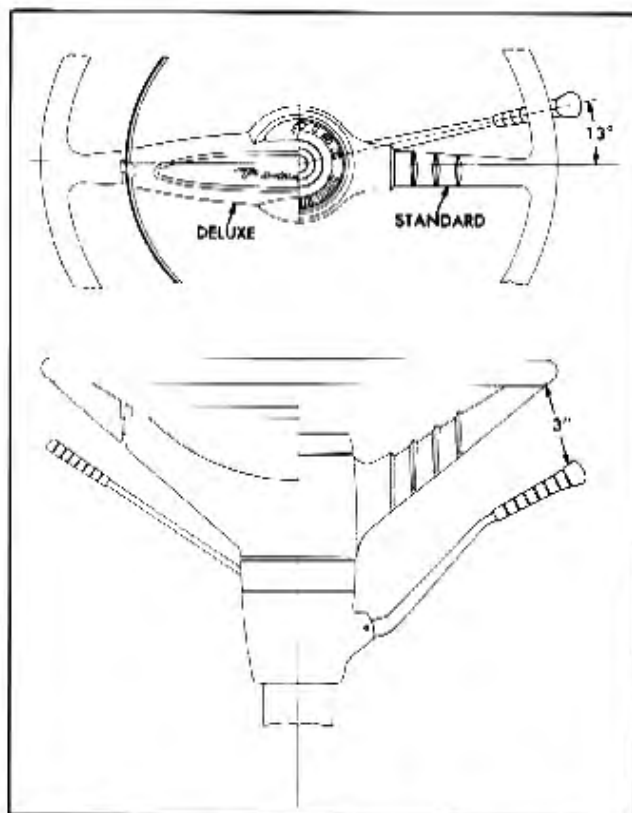

Fig. 7-3 Gearshift Lever Adjustment

5. Inspect propeller shaft yoke for nicks, burrs or scratches which would cut new seal or cause seal to leak or damage bushings in rear bearing retainer.

6. Apply sealing compound (Permatex No. 3 or equal) to outside of oil seal.

7. Install new oil seal in bearing retainer using Tool J-1354 (Fig. 7-4).

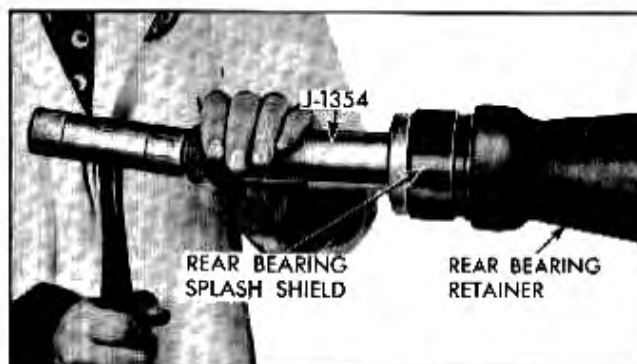

Fig. 7-4 Installing Oil Seal

REMOVE AND REPLACE STEERING COLUMN SHIFT LINKAGE

REMOVE

1. Remove horn button or ring and steering wheel. To remove deluxe horn ring, remove four screws which retain horn ring covers to bottom of horn ring. Then remove covers and lift off horn ring.

2. Remove direction signal switch, actuator rod and actuator housing (see section 12).

3. Remove gearshift lever pivot pin by tapping out with punch and hammer and remove gearshift lever and anti-rattle spring.

4. Pull upper bearing support out of mast jacket (Fig. 7-5).

5. Remove two flat washers and wave washer from shift tube (Fig. 7-5).

6. Disengage and remove bearing support and direction signal lock plate (Fig. 7-5).

7. Slide gearshift lever housing off end of steering column.

8. Slide gearshift lever housing retainer plate out of mast jacket (Fig. 7-6).

9. If disassembly is being made with steering column assembly in car, it will be necessary to remove left engine splash apron and power brake unit so that lower end of steering column jacket can be reached from beneath car.

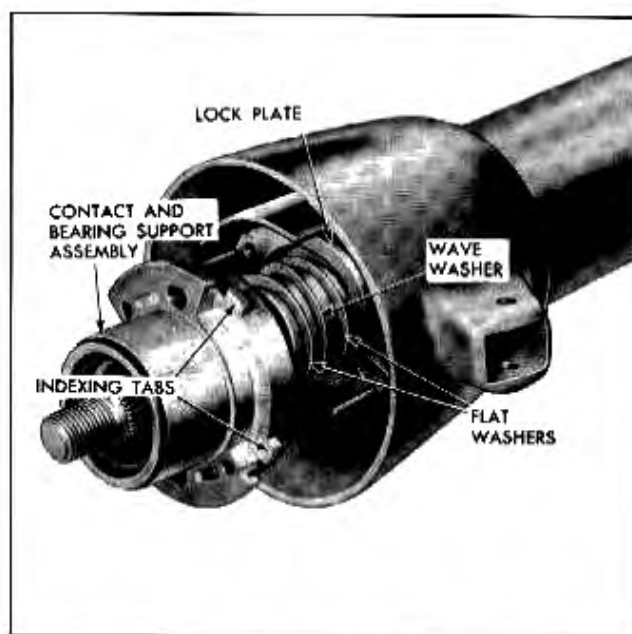

Fig. 7-5 Contact and Bearing Support Assembly

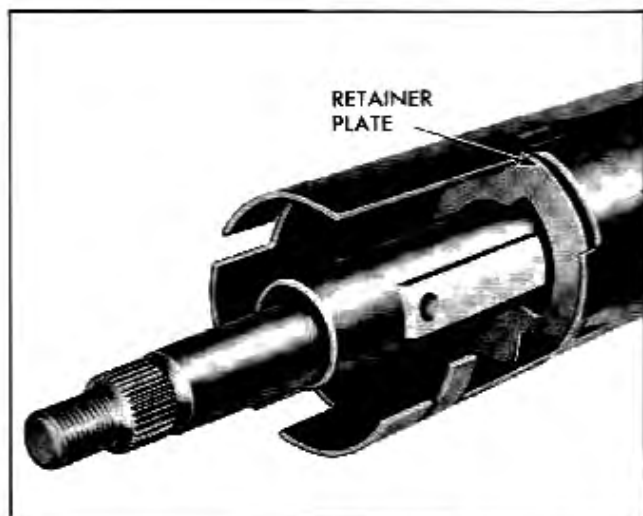

Fig. 7-6 Gear Shift Lever Housing Retainer Plates

10. Remove transmission control rods from levers. Hydra-Matic cars have only shift lever.

11. On Synchro-Mesh cars remove gearshift selector lever and bracket by removing two retaining screws (Fig. 7-7). When selector lever and bracket assembly have been removed, pivot pin can be pulled out to disassemble lever from bracket.

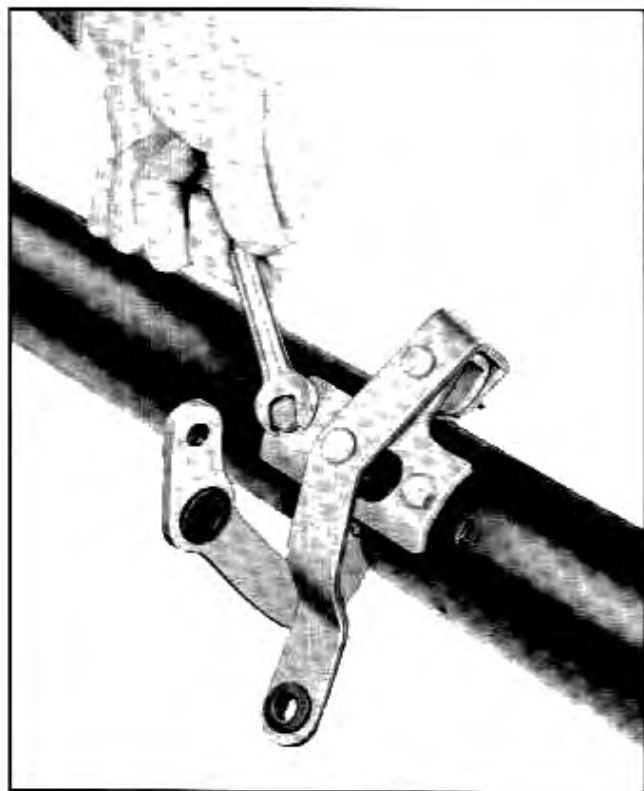

Fig. 7-7 Lower Gearshift Levers

12. Remove shift lever from tube yoke by loosening screw about $\frac{1}{8}$ " with an open end wrench and moving lever down and out. Gearshift tube can be held downward by means of screwdriver inserted through selector lever opening (Fig. 7-8). Attaching screw need not be completely removed from bracket since re-installation is greatly simplified if screw is left in.

13. Gearshift tube can now be withdrawn from top of steering column jacket. Insulating pads will come out with shift tube when it is removed.

14. Remove gearshift tube return spring, lower seal retainer and lower seal if they are to be replaced.

REPLACE SHIFT LINKAGE

1. Slide lower felt seal and retainer down inside steering column jacket against shift tube lower bearing plate. Coat both ends of shift tube return spring with Lubriplate 105 and drop it down steering column jacket into place against lower seal retainer with large end down.

2. Apply a thin coat of Lubriplate 105 to bearing surfaces at both ends of gearshift concentric tube including key at upper end and selector collar groove in which selector lever pin rides. Position insulating pads around shift tube beneath retainer plate and install shift tube in steering column with gearshift lever yoke facing opening in upper end of steering column.

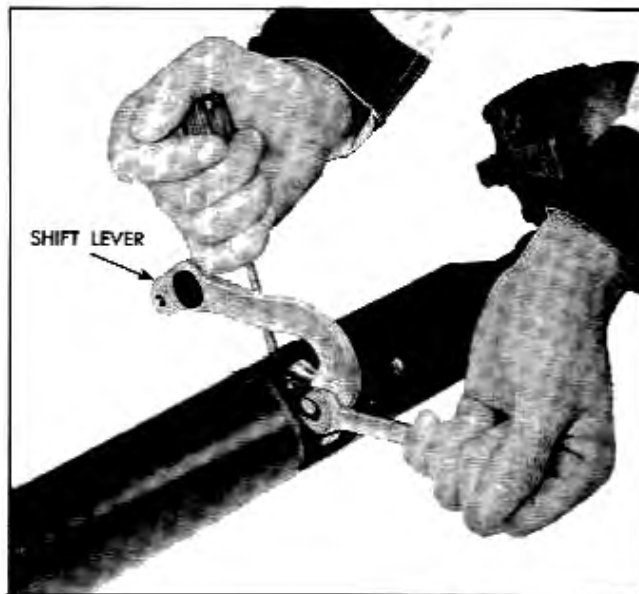

Fig. 7-8 Removing Lower Shift Lever

3. With screw started in gearshift lower lever, position lever against bottom of lower lever drive plate engaging driving lugs and extrusion at screw boss and tighten cap screw securely. Shift tube can be held down by means of screwdriver inserted through selector lever opening (Fig. 7-8).

4. On Synchro-Mesh models coat selector lever pivot pin with Lubriplate 105 and assemble selector lever to bracket. Install pivot pin so cotter pin is on side toward steering column jacket (Fig. 7-9).

5. Place Synchro-Mesh selector lever and bracket assembly on steering column jacket making sure selector lever pin engages collar on gearshift tube. Install attaching screws securely.

6. Connect transmission selector rod trunnion and shift rod clevis to their respective levers. Use flat washer on each side of selector rod insulator.

7. Replace power brake unit and left engine splash apron if unit is being assembled on car.

8. Position gearshift lever housing retainer plate in mast jacket positioning notch and indexing tab as shown in Fig. 7-6. (If installed upside down the gearshift tube will be locked from rotating.)

9. Slide gearshift lever housing over steering column against retainer plates.

10. Position lock plate into cutouts in steering column (Fig. 7-5).

11. Slide flat washer, wave washer, and second flat washer over shift tube against lock plate (Fig. 7-5).

12. Slide upper bearing support into place, indexing tabs (Fig. 7-5) on sides of support with opening in mast jacket. **NOTE:** If steering shaft upper bearing is replaced it should be located in bearing support so horn wire passes through opening shown in Fig. 7-10.

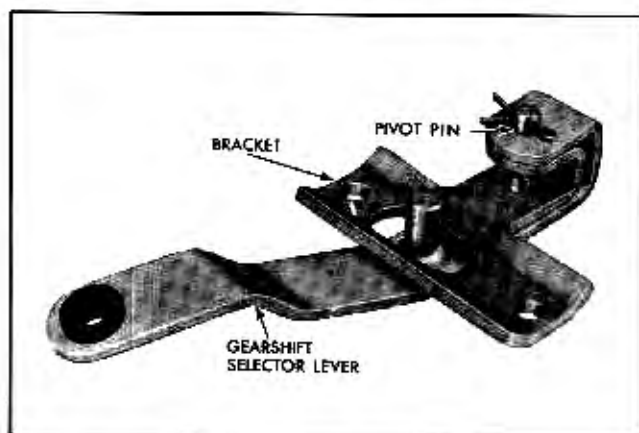

Fig. 7-9 Selector Lever and Bracket Assembly



Fig. 7-10 Contact and Bearing Support Assembly

13. Position gearshift lever anti-rattle spring (coil spring) in bore in support. Position lever in its support and install gearshift lever fulcrum pin. (Feeler stock can be used to guide lever over spring.)

14. Install direction signal actuator housing and attach with three screws.

15. Reassemble direction signal actuator rod, switch and install steering wheel.

REMOVAL OF TRANSMISSION

1. Disconnect speedometer cable, gearshift selector rod and control rod.

2. Disconnect rear universal joint. Use tape or a rubber band if retainer strap has been removed to prevent trunnions from slipping off universal joint spider.

3. Remove propeller shaft by sliding it to rear off transmission main shaft splines.

4. To give clearance for removing upper cap screw holding transmission to clutch housing, remove transmission shift lever spring yoke and extension. Remove shift lever screw while holding shift lever in neutral (center position) to avoid damage to shift levers on shaft inside transmission. Remove shift lever.

5. To give clearance for removing lower cap screw holding transmission to clutch housing, remove transmission outer selector lever.

6. Remove transmission upper cap screws and install two transmission guide pins (pins can be made by cutting the heads off two transmission cap screws and sawing a screwdriver slot in the ends.) **CAUTION:** Guide pins must be used, since they support transmission and prevent distortion of clutch driven plate hub when lower transmission cap screws are removed.

7. Remove lower cap screws and move transmission to rear, bringing rear bearing retainer into intersection of frame "X" members until main drive gear is free, then lower to floor. **CAUTION:** Use care to avoid getting dirt into front bearing when pulling transmission away from clutch housing.

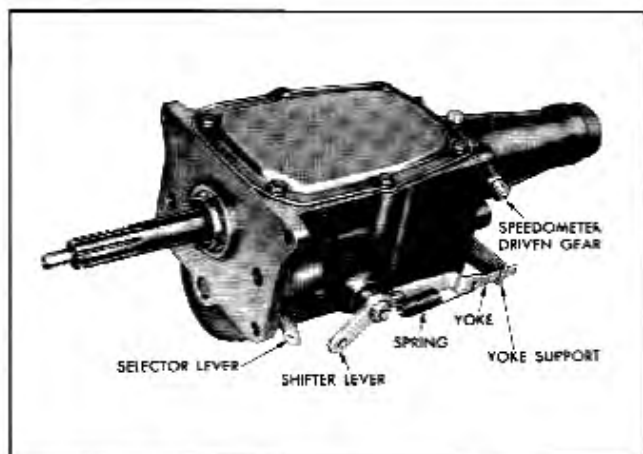

Fig. 7-11 Synchro-Mesh Transmission

DISASSEMBLY OF TRANSMISSION

1. Thoroughly clean all dirt from exterior of transmission to avoid getting dirt into bearings when transmission is opened.

2. Remove transmission cover and gasket, selector lever, and shifter lever and yoke.

3. Remove speedometer driven gear, then remove rear bearing retainer, gasket, and shifter lever spring yoke support from transmission case (Fig. 7-11).

4. Place transmission in second gear and pull mainshaft back until rear bearing is clear of case. **NOTE:** If fit between bearing and transmission case is tight, it may be necessary to tap second speed gear as shown in Fig. 7-12.

5. Disengage shifter yoke from synchronizer and lift front end of main shaft enough to remove synchronizer from shaft as shown in Fig. 7-13. **NOTE:** The counterbored end of synchronizer clutch must face second speed gear when replaced.

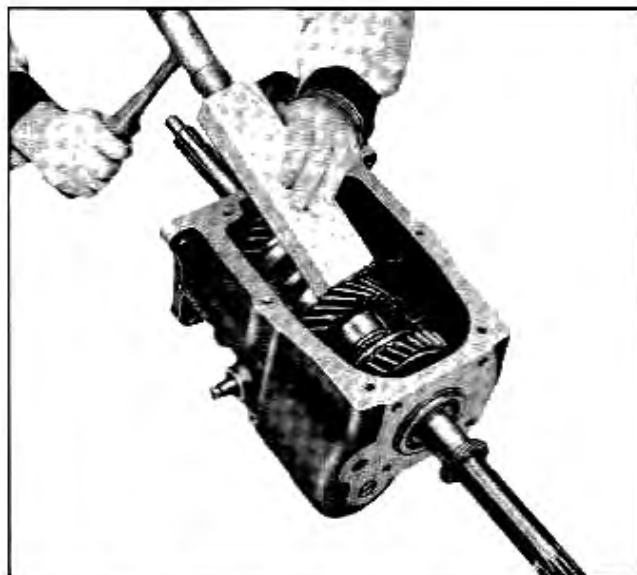

Fig. 7-12 Freeing Transmission Rear Bearing from Case



Fig. 7-13 Removing Synchronizer from Main Shaft

6. Remove snap ring holding second speed gear to main shaft using tool KMO-630 (Fig. 7-14).

7. Slide second speed gear and thrust washers off end of main shaft. Note wire spacer ring installed in bottom of snap ring groove.

8. Remove snap ring holding low and reverse gear to main shaft.

9. Slide low and reverse gear off main shaft by pulling shaft out through rear of transmission case.

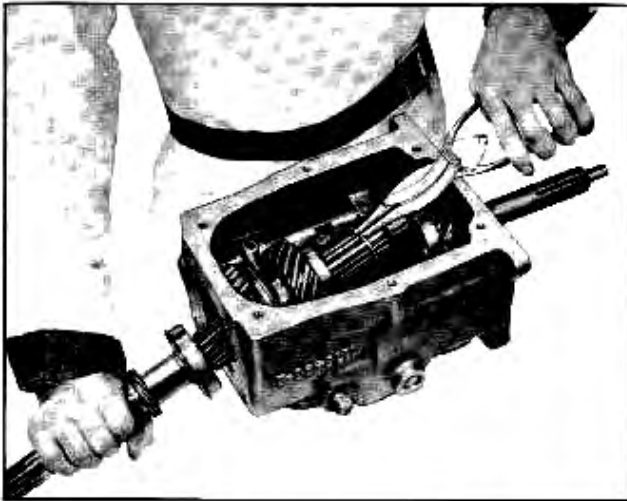

Fig. 7-14 Removing Second Speed Gear Snap Ring

10. Place transmission levers in neutral and remove set screws using Tool J-2895 holding shifter yokes and shifter levers to their respective shafts (Fig. 7-15). **NOTE:** Each shifter shaft is in neutral when the notch for the shifter lever is directly above the selector shaft.

11. Push second and third shifter shaft out through front of transmission case, taking care to prevent poppet ball and spring from flying out (See Fig. 7-15). Remove shifter yoke, ball and spring.

12. Pull selector shaft to left and remove interlock retainer from groove in right end of selector shaft and using a soft hammer drive the shaft out through right side of transmission case (See Fig. 7-16). The Welch

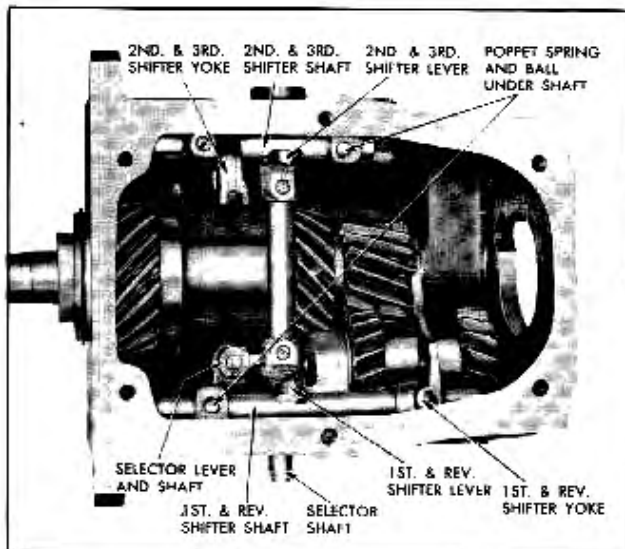

Fig. 7-15 Transmission Shift Mechanism

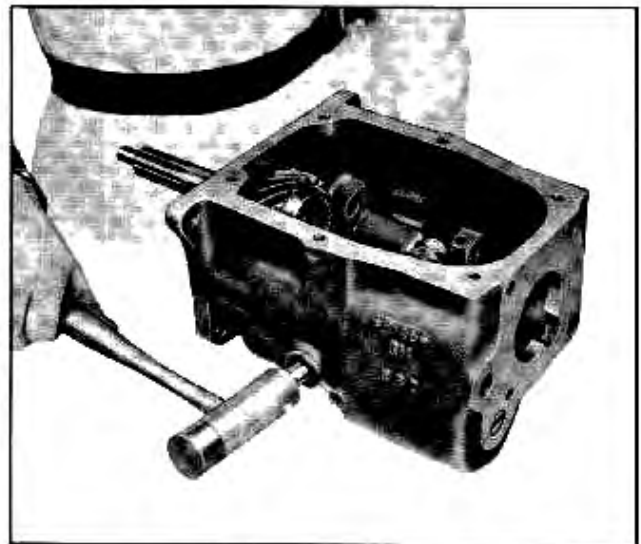

Fig. 7-16 Removing Selector Shaft

plug in right side of case will be driven out by the shaft. Do not allow shifter levers and interlock to drop into case. **CAUTION:** When replacing selector shaft, be sure to install from left side of case toward right in order to avoid damaging oil seal.

13. Taking care to prevent poppet ball and spring from flying out, push low and reverse shifter shaft out through rear of transmission case (See Fig. 7-15). Remove shifter yoke, poppet ball, spring, and low and reverse interlock pin.

14. Using punch drive counter gear shaft lock pin into the shaft, then drive shaft out through rear of transmission case using Bearing Loader Tool J-1001-A and a soft hammer (Fig. 7-17). Make sure Tool follows the shaft closely so that counter gear bearings and thrust washers will be held in place. Allow counter gear assembly to rest on bottom of case. Drive lock pin out of shaft.

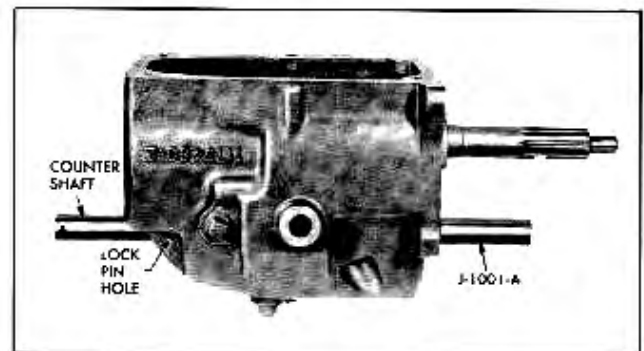

Fig. 7-17 Driving Counter Gear Shaft Out of Transmission

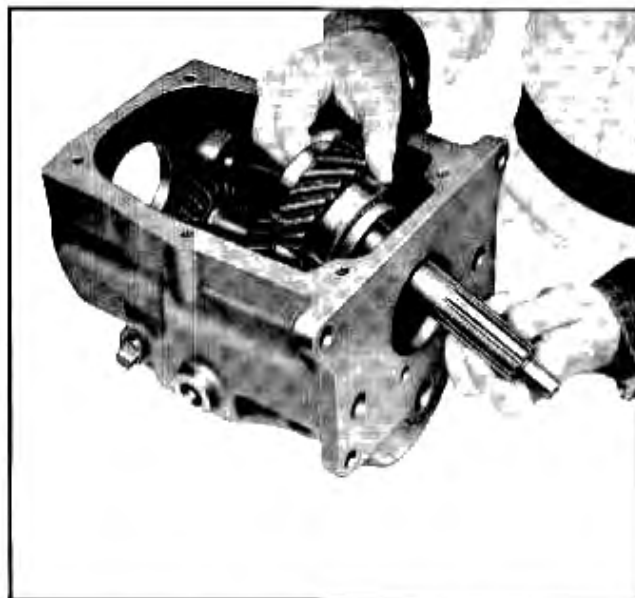

Fig. 7-18 Removing Main Drive Gear

15. Remove snap ring from main drive gear bearing and tap drive gear bearing assembly toward rear of transmission case to remove (See Fig. 7-18).

16. Carefully raise counter gear out of case so that bearing loader, bearings, and bearing retainer washer do not fall out. Remove all thrust washers. Note that a bronze and two steel washers are used at the rear (with bronze washer between the steel washers) and a large bronze washer, only, is used at the front.

17. Remove transmission inner selector lever and shaft, spring washer, flat washer, and oil seal from transmission case.

18. Drive reverse idler gear shaft lock pin into shaft and drive shaft out of rear of case (Fig. 7-19). Drive lock pin out of shaft. NOTE: Slot on end of shaft is for aid in locating drive pin hole on installation.

19. Remove reverse idler gear and thrust washers.

SERVICING COUNTER SHAFT ASSEMBLY

1. If it is necessary to service bearings, spacer tube or retainer washers (Fig. 7-20) always place tool J-1001-A in the cluster gear to hold needle bearings in place on reassembly.

2. Assemble bearing spacer tube and bearing inner retainer washers over tool J-1001-A.

3. Assemble a sufficient number of bearings under end of tool so it is evenly spaced in bore of gear.

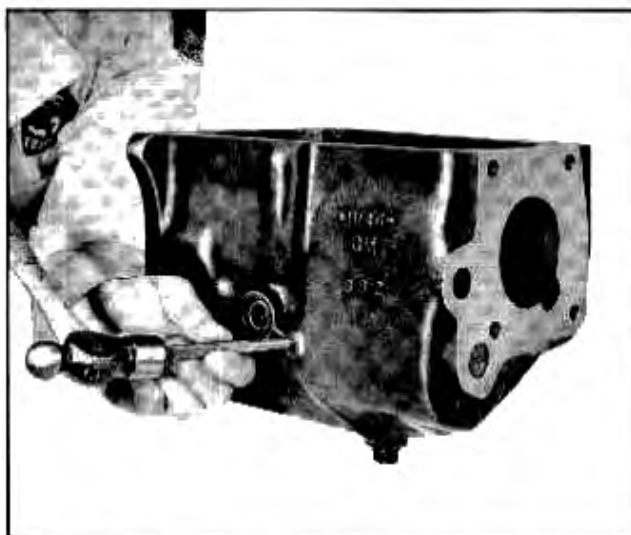

Fig. 7-19 Driving Reverse Idler Gear Shaft Lock Pin Into Shaft

4. Finish assembling a total of 26 bearings at each end of gear.

5. Install outer bearing retainer washers and thrust washers. Larger diameter thrust washer goes at front, smaller washers (two steel and one bronze) go to rear.

6. Leave Tool J-1001-A in place until gear is assembled into transmission case.

SERVICING MAIN DRIVE GEAR

1. Remove snap ring, washer, and oil slinger holding main drive gear bearing to gear (Fig. 7-21).

2. Remove bearing by jarring shaft on block of wood.

3. Remove wire lock ring, washer and 14 roller bearings from counterbore in gear. To replace, reverse sequence of removal operations. CAUTION: Press on inner race of bearing when installing using tool J-6133-A.

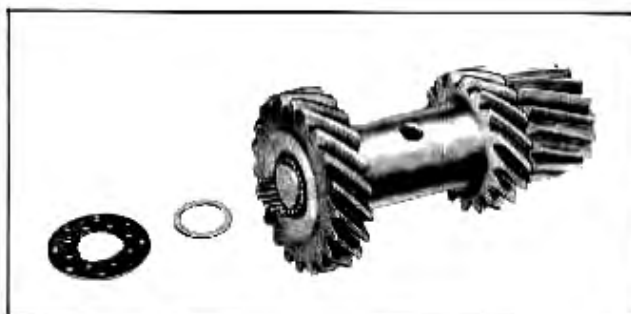

Fig. 7-20 Counter Shaft Assembly

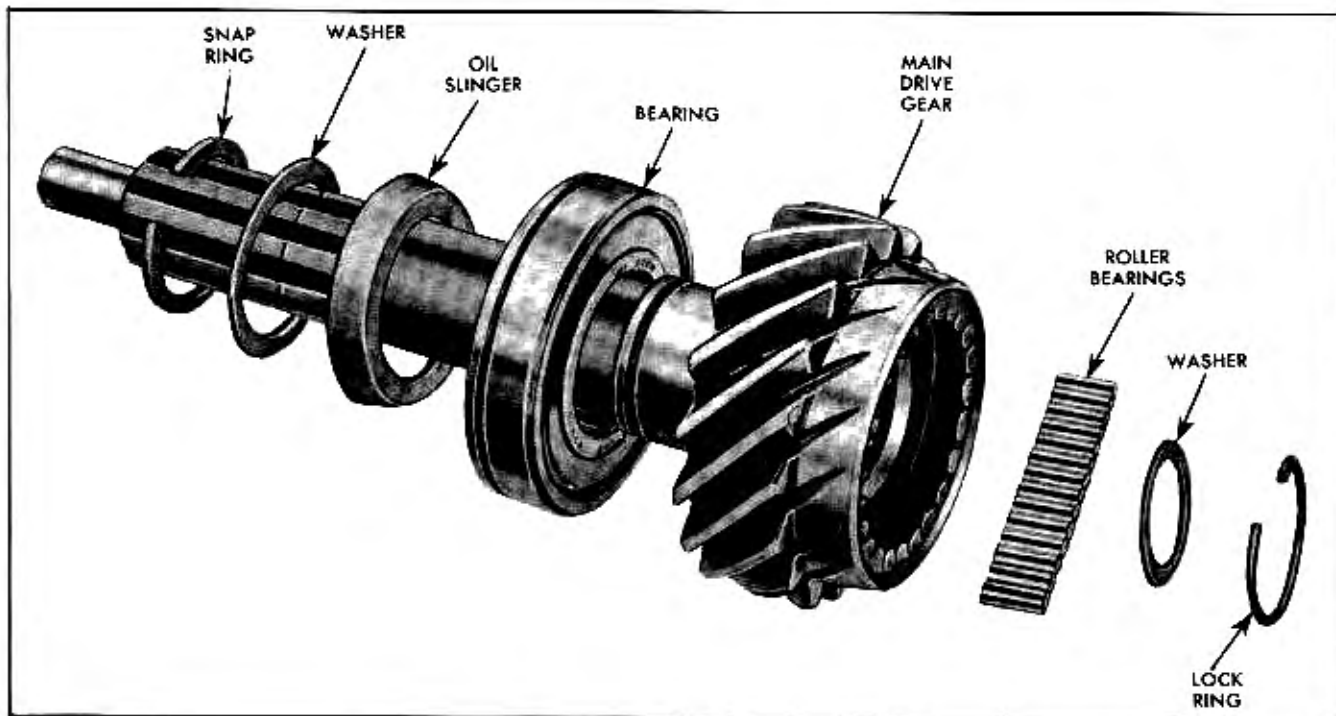

Fig. 7-21 Main Drive Gear and Front Bearing Assembly

SERVICING MAIN SHAFT

1. Press off speedometer drive gear as shown in (Fig. 7-22).

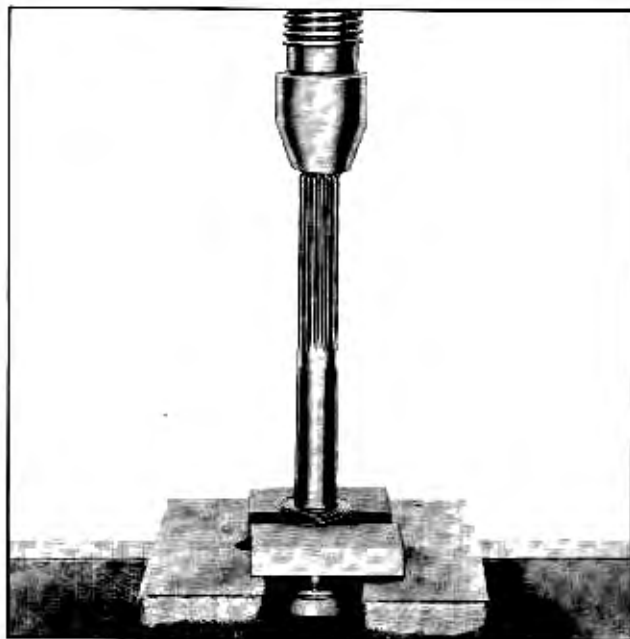

Fig. 7-22 Pressing Speedometer Drive Gear Off Main Shaft

2. Remove spacer from mainshaft and remove rear bearing snap ring using tool J-1041 (Fig. 7-23).



Fig. 7-23 Removing Rear Bearing Snap Ring

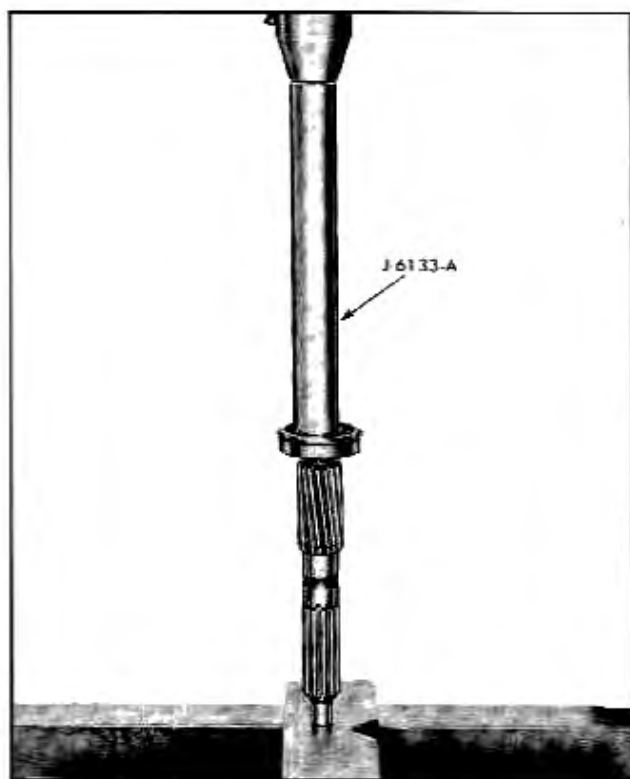

Fig. 7-24 Pressing Rear Bearing on Shaft

3. Press off rear bearing in same manner as speedometer drive gear.

4. To assemble new bearing to shaft press on inner race of bearing using tool J-6133-A as shown in (Fig. 7-24). Bearing should be against shoulder on shaft.

5. Install snap ring and speedometer gear spacer on shaft.

6. Press speedometer drive gear (Fig. 7-25) on shaft against spacer using tool J-6133-A.

SERVICING REAR BEARING RETAINER SEAL

1. Remove shield from rear bearing retainer.
2. Remove seal from rear bearing retainer.
3. Coat outer diameter of new seal with Permatex #3 or equivalent.
4. Line up new seal over bore in housing and tap lightly on outer edge to start seal in place.
5. Finish driving seal into retainer housing, using Tool J-1354.
6. Replace shield.

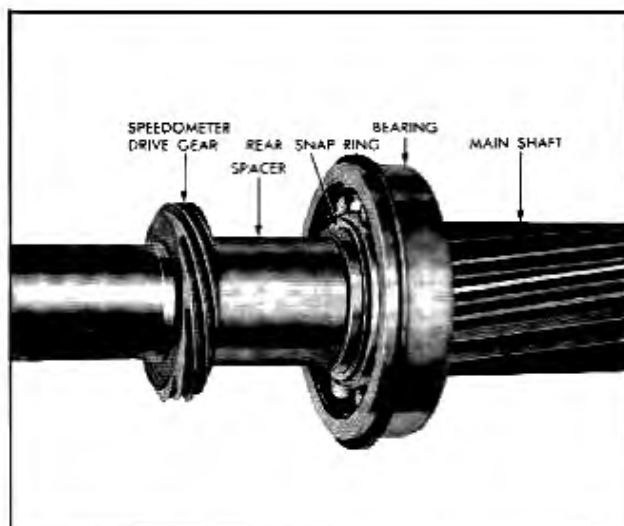

Fig. 7-25 Transmission Main Shaft Assembly

SERVICING SYNCHRONIZING CLUTCH

The synchronizing clutch detent springs (Fig. 7-26) are serviced separately and may be replaced, if necessary. Push synchronizing coupling off center of springs and pry each spring loose from gear and push out of groove. After the old springs have been removed, the new ones should be placed over the clutch and the synchronizing coupling pulled up into place over clutch.

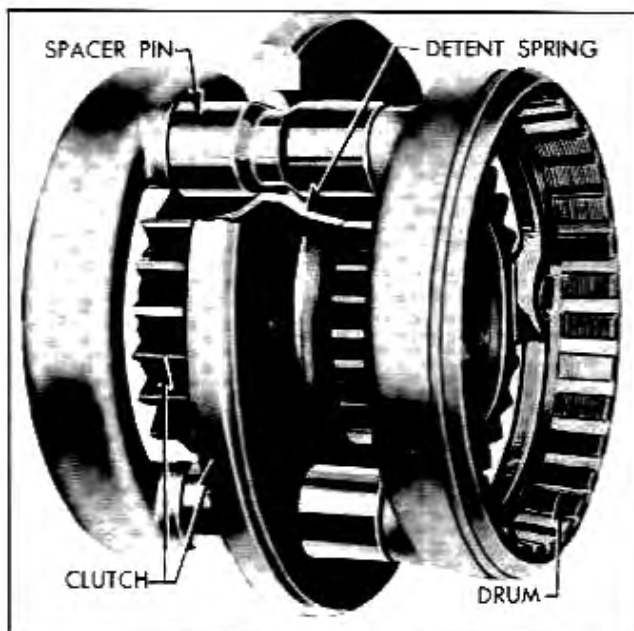

Fig. 7-26 Synchronizing Clutch Assembly

REPAIRS

REPLACEMENT OF REAR BEARING RETAINER BUSHING

1. Remove shield from rear bearing retainer.
2. Remove seal from rear bearing retainer.
3. Press bushing from rear bearing retainer using Tool J-6399.
4. Press new bushing into rear of bearing retainer using Tool J-6399 (Fig. 7-27).
5. Position new seal in bore of housing and drive in place using Tool J-1354.
6. Install shield.

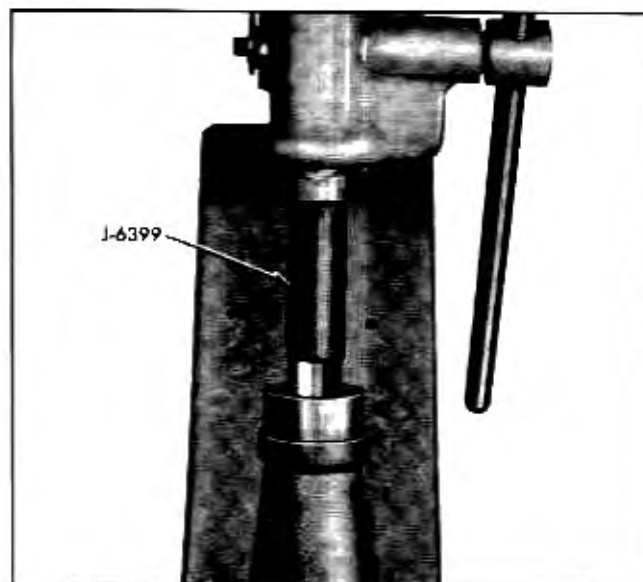

Fig. 7-27 Pressing Bushing Into Rear Bearing Retainer

CLUTCH HOUSING ALIGNMENT

CHECKING ALIGNMENT—When a new clutch housing is installed, or when a very noisy transmission or transmission jumping out of high gear indicates possible housing misalignment, the following procedure should be followed to check clutch housing alignment.

1. Remove transmission (page 7-5) and clutch (see page 6C-1).

2. Install alignment checking tool J-5128 and install dial indicator on stem of checking tool. Arrange hole attachment of dial indicator so its forward tip contacts inside diameter of pilot hole in clutch housing (which front transmission bearing enters when transmission is in place) as shown in (Fig. 7-28).

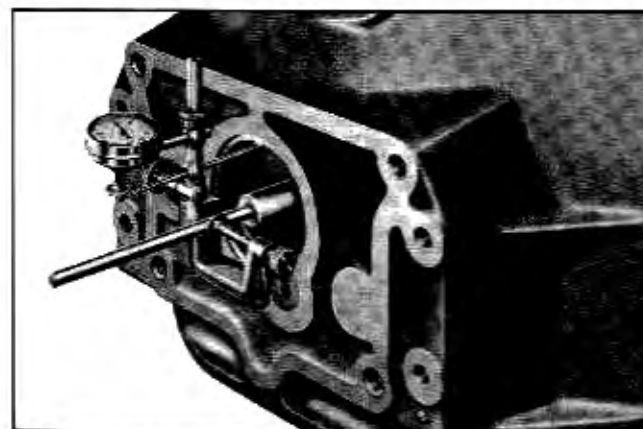

Fig. 7-28 Dial Indicator Positioned for Checking Housing Hole

3. Check location of hole in clutch housing as follows:

- a. Check horizontally: Rotate crankshaft to place dial indicator tip at point A, Fig. 7-29. Set dial at 0. Rotate crankshaft until indicator spindle is at B directly opposite point A. Indicator reading at B must not be more than .005" on either side of initial reading indicating that center of housing hole is within .0025" on either side of center of flywheel.

- b. Check vertically: Rotate crankshaft to place dial indicator tip at point C, Fig. 7-29. Set dial at .014". Rotate crankshaft until indicator spindle is at D directly under C. Indicator reading must be between .010" and .000" indicating center of hole in housing is .002" to .007" below center of flywheel.

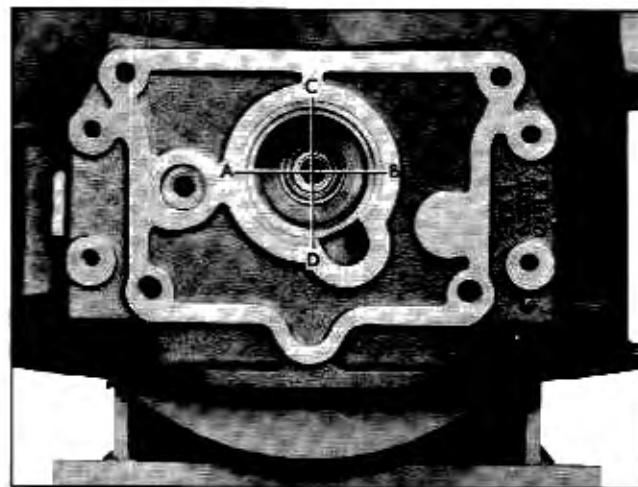

Fig. 7-29 Indicate Positions for Checking Hole

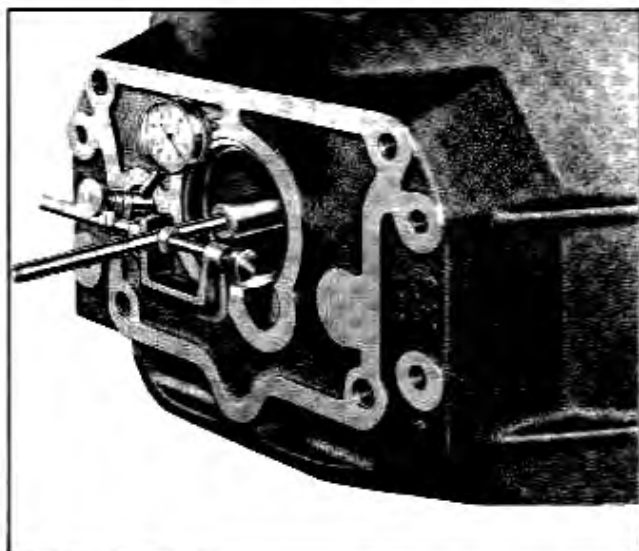

Fig. 7-30 Dial Indicator in Place to Check Face

4. Check squareness of face of housing as follows:

a. Change indicator location so stem of indicator contacts rear face of flywheel housing $\frac{3}{4}$ " from edge of hole (or $2\frac{3}{8}$ " radius from center of hole) as shown in Fig. 7-30.

b. Rotate crankshaft and check total indicator reading which should not exceed .004".

If any of the above checks show clutch housing to be misaligned, replace with new housing and re-check alignment.

ASSEMBLY OF TRANSMISSION

1. Position reverse idler gear and bronze thrust washers into transmission case with oil hole to front of case.

2. Install idler gear shaft until the front of the shaft picks up the front thrust washer and just starts into the inner support. Coat the protruding end of the shaft with Permatex #3 or other non-hardening sealer and complete installation of shaft making sure that lock pin hole in shaft lines up with hole in case. **NOTE:** Slot in end of idler shaft is used to line up shaft and hole.

3. Install a new lock pin coated with sealing compound to prevent leaks. Drive lock 1" below surface of boss on case.

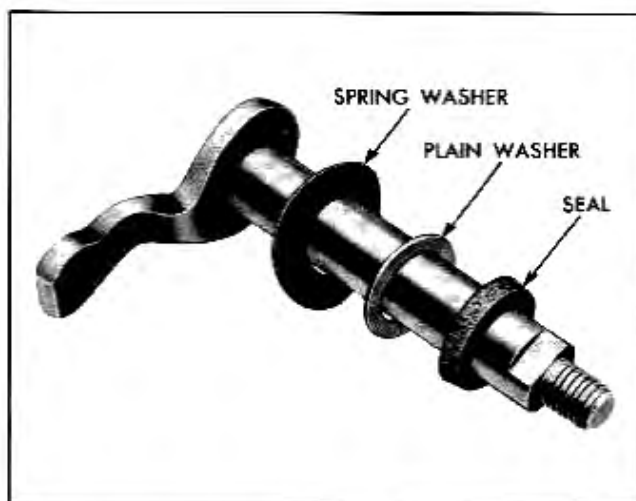

Fig. 7-31 Inner Selector Lever Shaft Assembly

4. Place spring washer, flat washer, and oil seal on selector lever shaft in order named, with crowned side of spring washer against flat washer (See Fig. 7-31). Apply lubriplate to shaft and assemble into transmission case. Then install outer selector lever.

5. Lay counter gear with bearings, Bearing Loader J-1001-A, retainer washers, and thrust washers into bottom of transmission case. Note that a small diameter bronze washer between two steel washers is used at the rear of the gear. A larger bronze washer, only, is used at the front.

6. Install main drive gear into front wall of transmission case and replace snap ring on bearing.

7. Mesh the teeth of the counter gear with teeth on main drive gear and reverse idler gear. Drive counter gear shaft into place with lock pin hole to rear from rear of transmission, being careful that it closely follows Bearing Loader J-1001-A so that bearings and washers are held in proper position. When front end of shaft just enters bore in front wall of transmission apply Permatex #3 or other non-hardening sealer to protruding end of shaft and to bore in front wall, then complete installation of shaft making sure that lock pin holes in shaft and case are in line.

8. Install a new counter gear shaft lock pin coated with sealing compound to prevent leaks. Drive pin flush with surface of transmission case.

9. Replace poppet ball and spring, interlock pin, and low and reverse shifter shaft with yoke.

10. Place low and reverse shifter shaft in neutral position. **NOTE:** The shifter shaft is in neutral posi-

tion when the notch for the shifter lever is directly above the selector shaft bore in transmission case.

11. Install a new welch plug, coated with sealing compound, in right side of transmission case.

12. Raise low and reverse interlock pin into groove in shifter shaft, then from left side of transmission case install selector shaft. Place low and reverse and second and high shifter levers on shaft, making sure selector lever engages notch in bottom of shifter lever. Install second and high interlock on shaft.

13. Install a new second and high interlock retainer on selector shaft.

14. Replace poppet ball and spring, yoke, and second and high shifter shaft over the second and high interlock.

15. Insert main shaft assembly through bore in rear of transmission case, slide low and reverse gear onto shaft and replace snap ring holding gear to shaft.

16. Install second speed gear rear thrust washer on main shaft. **NOTE:** Two splines on the main shaft are machined the entire length of the second speed gear. One of these splines is for lubrication and the other is for the tangs on the front and rear thrust washers. Both thrust washers must be installed with the tang in the same spline to prevent blocking the lubrication spline.

17. Install second speed gear on main shaft.

18. Install wire spacer ring in main shaft snap ring groove if removed. Install front thrust washer with tang in same spline as tang on rear thrust washer and install snap ring on main shaft.

19. Install synchronizer with counterbored end of clutch next to second speed gear, engage second and high shifter yoke with synchronizer and low and reverse yoke with low and reverse gear. Finish installing mainshaft assembly.

20. Replace set screws securing shifter levers and yokes to their respective shafts. J-2895 Shifter Fork Lock Screw Remover can be used to tighten screws.

21. Use new gasket and install rear bearing retainer to transmission case, sealing cap screws with sealing compound. (Install shifter lever spring yoke support under lower left cap screw.)

22. Install new top cover gasket and replace cover and spring clip.

23. Install speedometer driven gear.

24. Install selector lever and shifter lever, yoke and spring assembly (Fig. 7-11).

TRANSMISSION INSTALLATION

If transmission was reported as being very noisy or jumping out of high gear, misalignment between transmission and clutch housing may be present. Check as indicated in "Repairs" page 7-11 before installing transmission.

1. Install two transmission guide pins in upper cap screw holes in flywheel housing as was done when transmission was removed from car.

2. Place new transmission to clutch housing gasket over two guide pins and then install transmission entering guide pins in two upper cap screw holes to guide transmission into place and also support it so as to prevent distortion of clutch driven plate. Install two lower transmission to clutch housing cap screws; remove guide pins and then install two upper cap screws. **CAUTION:** When installing transmission do not try to force transmission main drive gear into clutch driven plate hub as damage will result. Release clutch by applying force to throw out fork and realign driven plate with a spare transmission main drive gear.

3. Install transmission shift lever spring, yoke, and extension and then install shift lever, lockwasher and screw. Apply Lubriplate 105 to spring extension ends and hole in shift lever; coat yoke end on all sides (where it enters yoke support at rear bearing retainer) and yoke spring hole with Lubriplate 105.

4. Install selector and control rods on shift and selector levers at transmission. Coat holes in levers with Lubriplate 105 before inserting rods.

5. Apply light coating of engine oil to spline on transmission main shaft and slide propeller shaft on spline.

6. Fill case with $2\frac{1}{2}$ pts. lubricant and $\frac{3}{4}$ pts. in rear bearing retainer through speedometer sleeve hole. (Extreme Pressure Lubricant or Multi-Purpose Gear Lubricant S.A.E. 80 or 90.)

7. Install speedometer driven gear, sleeve, and shaft assembly on rear bearing retainer.

8. Install speedometer cable.

9. Connect rear universal joint to companion flange, tightening "U" bolts to 14-20 lb. ft. torque. Use new lock plates under nuts and see that tabs are bent up against nuts to lock them.

TROUBLE DIAGNOSIS AND TESTING

TROUBLE	REMEDY
1. Hard shifting or blocking out.	Check for free clutch release and observe driver habits to insure that driver gets full release of clutch. A clutch that drags will cause blocking out of second and high gear. Also, may be caused by either shift control linkage on steering column or in transmission. Disconnect control and selector rods to isolate. Check for binding at rod rubber grommets. If in transmission, disassemble and check for bind in shift shafts, selector shaft, seals, etc. On blocking out, check synchronizing drums and cones on gears for burrs and scores and replace defective parts.
2. Low and reverse gear clash.	Shifting into low or reverse too rapidly; depress clutch pedal and allow time for clutch disc to stop spinning. Check for improper clutch pedal free travel and adjust to 1".
3. Noise in neutral with engine running and car standing.	Engage and disengage clutch to see if noise is actually in transmission or elsewhere. If in transmission, noise can come from main drive gear and bearings, reverse idler gear, main shaft pilot bearing in main drive gear, or second speed gear. A regular clicking noise usually indicates a nicked bearing or gear. Replace defective parts.
4. Noisy gears.	Some gear noise is normal in all but high gear. Compare car to others to see if noise is average or excessive. If excessive, drive in different speeds to determine which gears are noisy and replace. Misaligned fly-wheel housing; check as indicated on page 7-11.
5. Noisy shifting out of first or reverse.	Some noise is normal, if shift is made slowly. Abnormal noise usually due to improper clutch pedal free travel. Check and adjust to 1".
6. Car jumps out of gear.	High gear jump out is usually due to misalignment of clutch housing. Second gear jump out is usually due to incompleting shift, worn jaw clutch teeth, or loose fit of synchronizer clutch on main shaft. See that shift lever is moved through full travel; replace worn parts.
7. Gearshift lever too close to steering wheel causing interference with hand, or too far away.	Adjust (page 7-2).
8. Gearshift lever not properly positioned in neutral.	Adjust (page 7-2).
9. Rattle or clicking noise in gearshift lever.	Remove excess clearance at pivot points by shims and see that control shaft anti-rattle spring (upper) is in place.

TROUBLE	REMEDY
10. Gearshift lever does not return to high speed side when placed in neutral position.	Check to see that control shaft spring is in place at lower end of control shaft. When car is new, the selector shaft seal sometimes drags on shaft so lever will not return promptly; with use, seal will smooth up.
11. Squeak at transmission end of control rod as gears are shifted.	Apply Lubriplate 105 on portion of selector shaft contacting over-center spring yoke. Lubricate transmission ends of control rod and selector rod.
12. Squeak at steering gear end of control and selector rods in cold weather.	Lubricate rubber grommets at steering gear end of rods with rubber lubricant. Apply coating of Lubriplate 105 to selector contact on selector collar.

SPECIFICATIONS

Type	Synchro-Mesh
Gear Material	Chromium Steel
Gear Reduction	
First	2.15 to 1
Second	1.37 to 1
Third	Direct
Reverse	2.28 to 1
Countershaft Bearings	Needle
Main Shaft Pilot Bearings	Needle
Idler Gear Bearings	Bronze Bushings
Second Gear Bearings	Bronze Bushings
Retainer Rear Bearing	Steel Back Babbitt Bushing
Main Drive (Clutch) Gear	Single Row Ball Bearing
Main Drive Rear Bearing	Single Row Ball Bearing
Lubricant Capacity	2½ Pints
Lubricant Level	Bottom of Filler Plug Hole

NOTE: If transmission has been disassembled add ¾ pint of lubricant to bearing retainer through speedometer sleeve opening in addition to the 2½ pints shown for lubricant capacity.

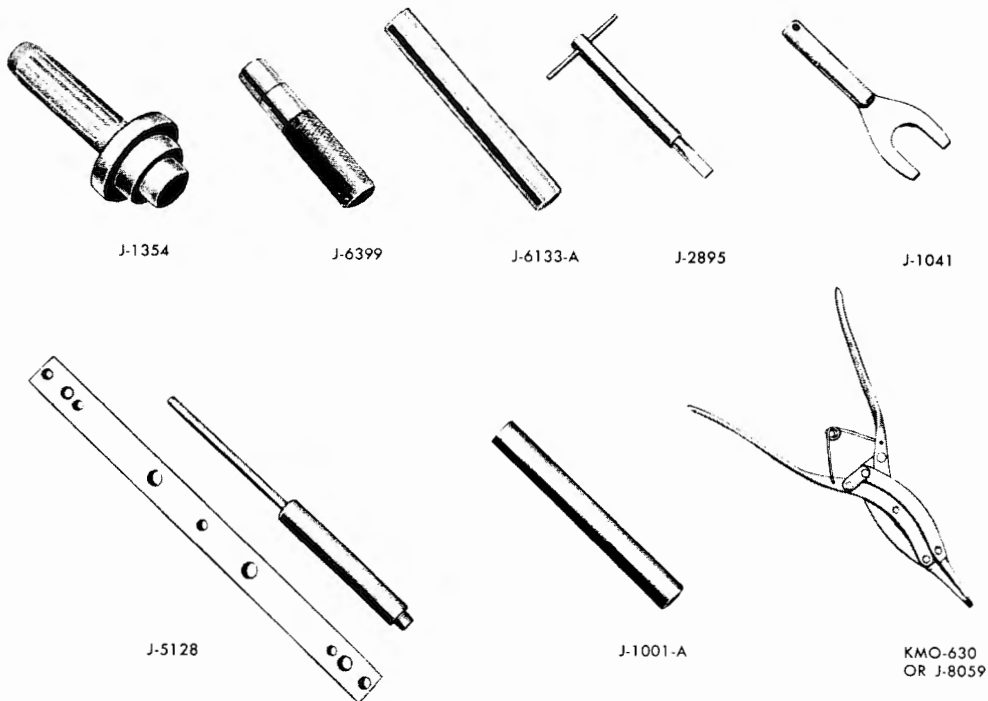

SPECIAL TOOLS—TRANSMISSION

- J-1354 Rear Bearing Retainer Oil Seal Installer
- J-6399 Rear Bearing Retainer Bushing Remover and Replacer
- J-2895 Transmission Shifter Fork Lock Screw Remover
- J-1041 Transmission Main Shaft Bearing Retainer Remover
- J-5128 Clutch Housing Align Tool (Use With Dial Indicator)
- J-1001A Transmission Countershaft Needle Bearing Loader
- KMO 630
or J-8059 Snap Ring Pliers
- J-6133A Rear Bearing Installer