

1956

PONTIAC

accessories

Designed and engineered to make your

Pontiac driving even more enjoyable!

214

215

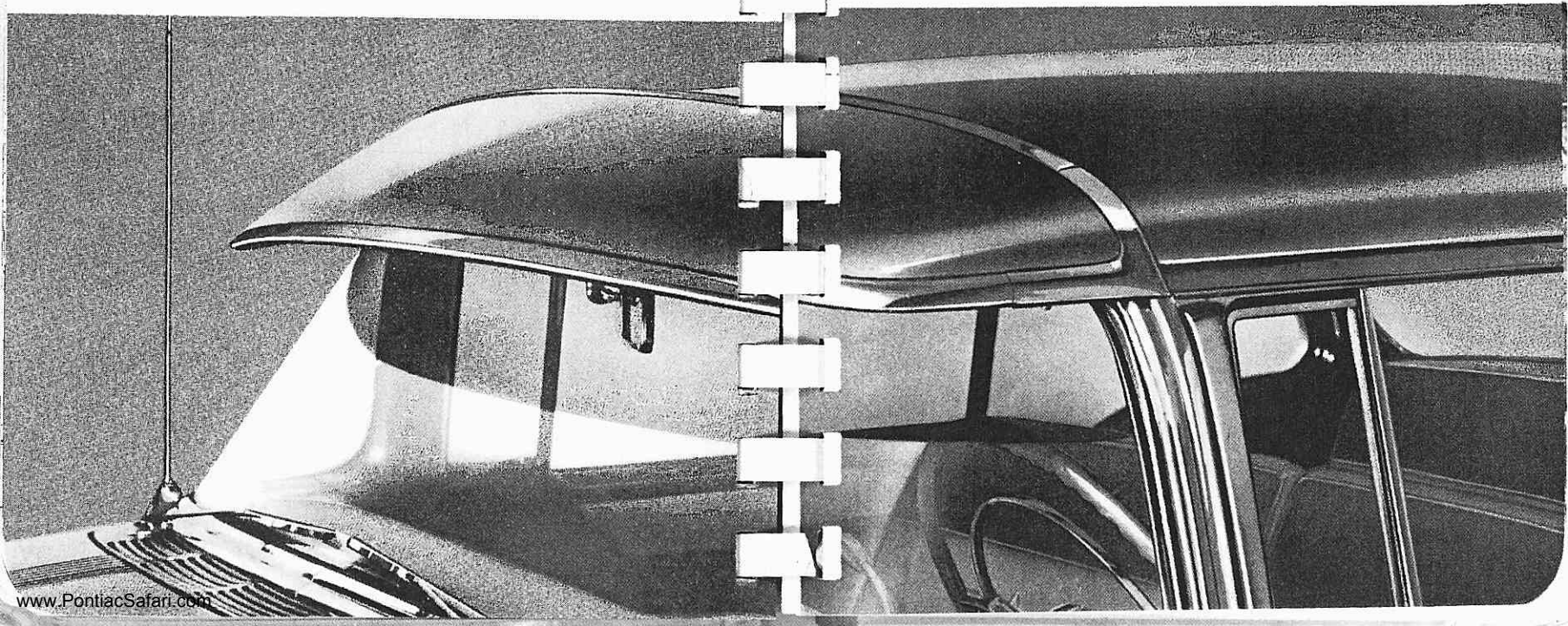



PONTIAC ACCESSORIES

cost you less by the group

When you have your Pontiac accessories installed at the factory, they are put on the car while it is being built and thus become a part of the assembly process. This means that you save not only on labor costs, but time as well! What's more, your accessories are custom-installed to your individual order and your Pontiac is delivered equipped and ready to go. So you see, it really does *cost you less* when you buy your Pontiac accessories by the group!

basic group

- Underseat heater and defroster
- Deluxe radio and antenna
- Back-up lamps
- Tilting non-glare rear-view mirror
- Oil-bath air cleaner
- Full-flow oil filter

convenience group

- Glove compartment lamp
- Visor vanity mirror
- Luggage compartment and trouble lamp
- Illuminated ash tray
- Instrument panel courtesy lamps
- Hand brake signal
- Underhood lamp
- Outside rear-view mirror

appearance group

- Exhaust deflector
- Lighted hood ornament
- No-Mar fuel door guard
- Rear fender shields

comfort group

- Windshield washers
- Latex foam seat cushions
- E-Z-Eye tinted safety glass

protection group

- Front bumper grille guards
- Rear bumper wing guards

BASIC GROUP

Certain accessories are basic to driving enjoyment, and for this reason, Pontiac has chosen six of the most-wanted accessories and put them in the Basic Group. Each one was skillfully designed to increase driving comfort and pleasure.

VENTI-HEAT UNDERSEAT HEATER AND DEFROSTER



Here is a system that works for you the year 'round . . . giving you warmth in winter and air circulation in summer. Large quantities of air, more free of dust and fumes, are admitted through the air intake in the cowl, and are brought into the passenger compartments through outlets located under the front seat. The beautiful controls are located on either side of the steering column, and the air and temperature controls are individually operated by protruding ball-ended levers which move vertically. Relevant con-

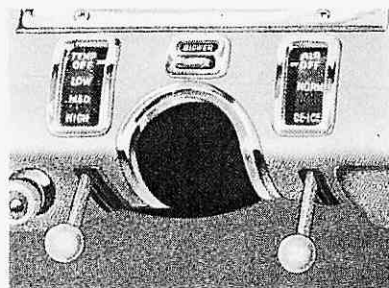

BASIC GROUP

trol panels are plainly marked and are illuminated with glowing white lighting for night driving. The blower switch, located between the vertical heater and ventilation control panels, operates horizontally. During the winter, the AIR control should be set at NORMAL and the TEMPERATURE control set at whatever warmth is desired. Outside air is then scooped up, warmed to the right degree and then evenly distributed under gentle pressure through underseat ducts to all parts of the car. The defroster now has two outlets which offer more efficient coverage of the windshield. In case ice has formed on the windshield, or perhaps during a severe snow storm, owner should move AIR control to DE-ICE and TEMPERATURE control to HIGH. In extremely cold weather, move the AIR control from NORMAL to DE-ICE until car is sufficiently warmed. For summer use, move the TEMPERATURE control to OFF, the AIR control to NORMAL and, by using the blower to increase the air intake, greater distribution of air results. The venti-heat underseat heater-defroster may be individually ordered for factory installation.

PONTIAC DELUXE RADIO

This handsome accessory offers the finest in listening pleasure and has push button tuning with the capacity for five stations. The four-position tone control ranges from deep bass to sharp, clear treble and, with the built-in long-range power that this radio has, faraway stations are brought in with amazing clarity and signal strength. New dial design, including white marbled tuning knobs and white illumination for night driving, has also been incorporated in this radio for added beauty and convenience. The controls are centrally located within easy reach of all front seat passengers, and push buttons can be changed and reset to any desired station in a matter of minutes. Each button is pushed to the right and pulled out—then the station desired is dialed manually. Push button back in and the station is set exactly where you want it. Another handy feature of this handsome Pontiac radio is an indicator lamp which shows "ON" if the radio should be turned on without proper volume.

BASIC GROUP

A new "signal-seeking" radio, called the De Luxe Electramatic, is also available as an individual accessory (not part of the basic group) and is designed to give you automatic tuning of any available station in any locality by using a "selector bar" located above the radio dial. It is possible to get almost any number of listenable stations by turning a "sensitivity control" and pushing the "selector bar" . . . which will result in automatic tuning. A telescoping 57-inch antenna is available for both De Luxe and De Luxe Electramatic radios and mounts on the right front cowl to minimize obstruction of the driver's vision. Either radio for 1956 can be ordered for factory installation.

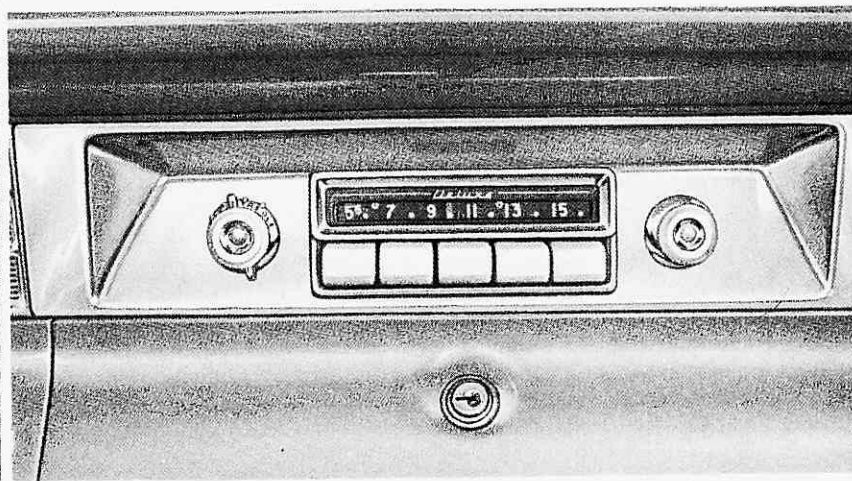

BASIC GROUP

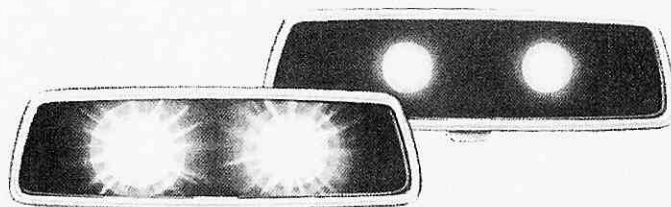

TILTING NON-GLARE, REAR-VIEW MIRROR

This rear-view mirror relieves driver's eyes of strain and makes night driving much safer and easier. By day it reflects a sharp, clear image of the road behind, and at night a tap on its positioning tab cuts the glaring reflection to a minimum. Extra-wide 8-inch size gives a wide view of the road behind and the entire mirror glass is enclosed in a chrome frame for fine appearance.



DUAL BACK-UP LAMPS

Designed to operate automatically whenever the motor is running and shift or selector lever is in reverse gear, these dual back-up lamps give warning to pedestrians and other drivers of intention to back up. Mounted just below the tail lights, these two 32-candlepower beams permit the driver to see what's behind him, help him avoid obstructions and steer safely out of narrow driveways or parking places. Can be individually ordered for factory installation—Group F.

BASIC GROUP



OIL-BATH AIR CLEANER

You can add years to the life of your engine and save costly repair bills even when operation is in the city, if you have one of these Pontiac oil-bath air cleaners on your new Pontiac. This carefully engineered unit utilizes a pool of oil to clean the air before it passes into the carburetor, thus serving to remove harmful dust and dirt that might otherwise enter the engine.

FULL-FLOW OIL FILTER



Pontiac's full-flow oil filter protects your engine from dirt and foreign particles that would otherwise flow into the lubrication system and cause undue engine wear or harmfully affect engine performance. Every drop of oil is directed through a filtering element that removes the foreign particles, and is then sent into the oil galleries. In case the filter becomes clogged with dirt, the oil is bypassed. This keeps the oil flowing until the dirty filter element has been replaced.

CONVENIENCE GROUP

This is the group that makes driving a Pontiac even more wonderful and enjoyable. The convenience group is very inexpensive, yet worth so much in safety and comfort.

GLOVE COMPARTMENT LAMP

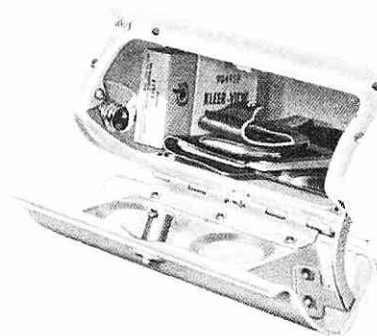

Pontiac's glove compartment lamp floods the interior with light the instant the glove compartment door is opened and shuts off automatically when the door is closed. Eliminates groping in the dark. The metal shade directs light into glove compartment and may be turned around to direct light for map reading. This handy accessory operates on a plunger switch to insure a positive light every time.

TRUNK AND UTILITY LAMP

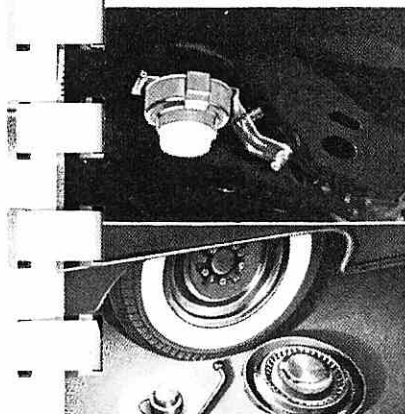

New for 1956, this convenient accessory turns on the moment the trunk lid is lifted, illuminating the luggage compartment automatically. You then have both hands free to load luggage or get at the spare tire. It is also possible to lift lamp from its mounting bracket and, by means of a 17-foot self-storing extension cord, use it for changing tires or as a warning light.

HAND BRAKE SIGNAL

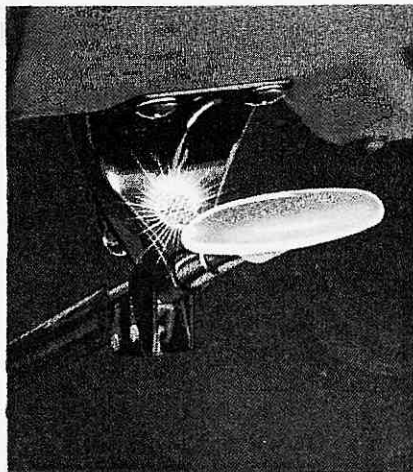

Mounted in the hand brake lever bracket, this signal flashes a bright red warning whenever ignition is turned on and brake is set. It will continue to flash this warning until the hand brake is released, which means that you avoid the danger of driving with hand brake on and possibly damaging the brakes. The red flasher is made of translucent and "reflectorized" red glass encircled in chrome.

UNDERHOOD LAMP

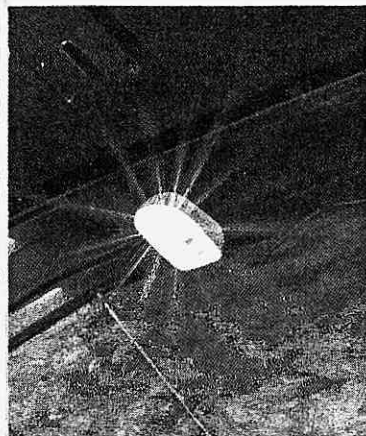

New for 1956, this underhood lamp is designed to give the driver the assistance of proper light while working under the hood at night. The lamp is mounted on the underside of the hood and a metal shade directs the light directly on the engine and the underhood interior. Lamp goes on automatically the moment the hood is lifted, and shuts off when the hood is closed. (An underhood and trouble lamp is available for use with Station Wagons.)

OUTSIDE REAR-VIEW MIRROR

Whether you're in the city or in the country, you'll find this outside rear-view mirror an invaluable aid to safe driving. It tells the driver when it is safe to pull out and pass and eliminates "blind spots" in rear vision. A quick glance is all that's necessary . . . the driver keeps his eyes focused on the road ahead. Securely attached to minimize vibration and give clear images, this handsome mirror is heavily chrome-plated to protect it against the elements. The reflecting surface is "Cromir" which prevents "blurring" and "ghosting" . . . reduces glare for easier night driving.

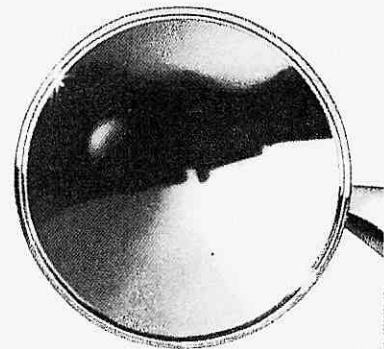

ASH TRAY LIGHT

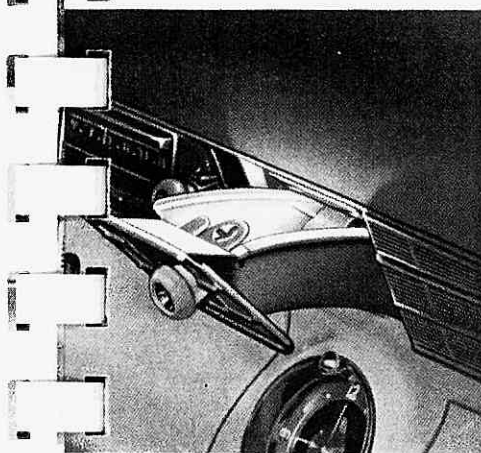

Pull the ash tray from its recess and it gives off a suffused glow for the convenience of smokers at night. Because of the small opening through which the light passes, it cannot distract the driver and yet gives enough light to guide smokers in finding the ash tray at night. Thus you avoid missing the ash tray which possibly could result in burned clothing or upholstery. When emptying the ash tray, the light remains in the instrument panel.

CONVENIENCE GROUP

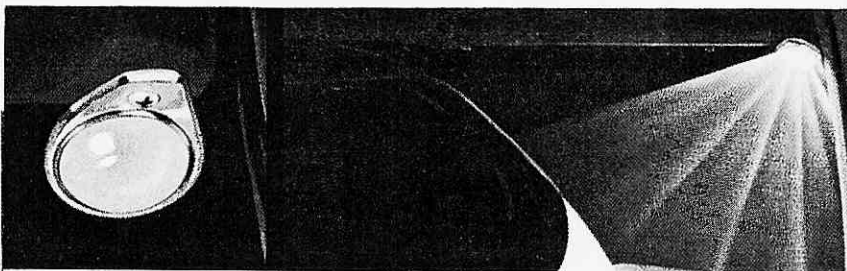

COURTESY LAMPS

Installed on both sides of the car beneath the instrument panel, these handy lamps flash on when the front doors are opened, throwing a strong beam of light to assist driver and passengers in and out of the car at night. They may also be operated manually by flicking a switch centrally located on the instrument panel. (Also available as an individual accessory.)



VISOR VANITY MIRROR

Here's something that really will be appreciated by the women. It's Pontiac's new 3½" by 10" mirror that clips easily to the underside of the inside sun visor and is ideal for repairing make-up, combing hair or checking appearance. Men will appreciate this accessory, too, especially salesmen on business trips—for shaving or checking appearance.

APPEARANCE GROUP

Give your car added sparkle and good looks with these inexpensive accessories in the Appearance Group. Not only do they give your car added beauty, but they do a good job of protection where needed, too.

EXHAUST DEFLECTOR

Finished in bright chrome plate, this deflector protects the rear bumper from discoloration by exhaust gases and adds a touch of beauty to your new Pontiac, too. It deflects gases down and away from the bumper, helps keep your chrome shiny and new looking.

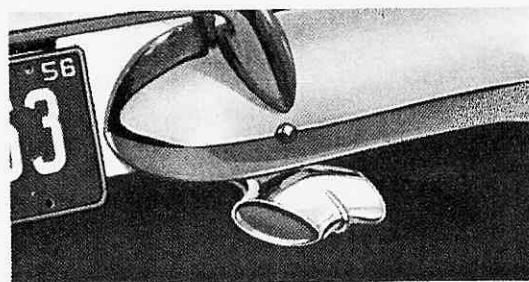

ILLUMINATED HOOD ORNAMENT

This new accessory continues the "V" motif as used in 1955, but the point of the "V" is now made of clear plastic which runs along the front edge of each wing. Midway between the point and wing tip, there are two bomb-like projections that give the hood ornament a "jet plane" appearance. The plastic section glows softly with suffused light whenever the lights are turned on to add distinction and another illuminated spot for safety. This accessory may be ordered for factory installation—Group MX.

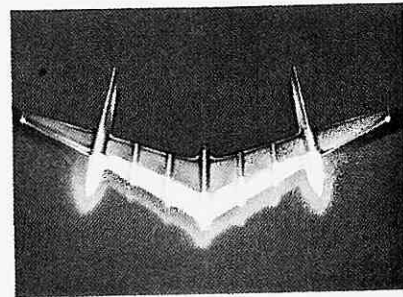

APPEARANCE GROUP

NO-MAR FUEL DOOR GUARD

New for 1956, this accessory curves around the vulnerable side of the gas tank filler door and prevents nicking and scratching by careless gas station attendants when they fill the tank. Smartly designed, it is made of stainless steel that won't rust or corrode.

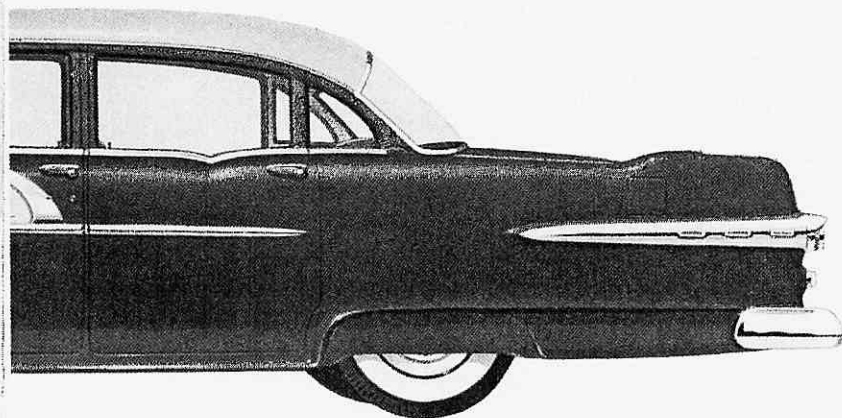
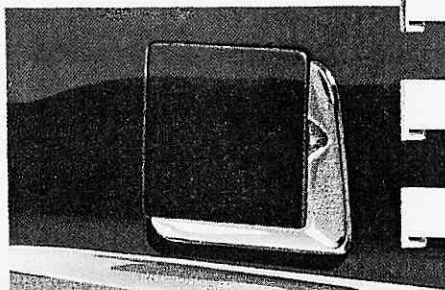

REAR FENDER SHIELDS

Pontiac's rear fender shields add a graceful note of beauty to the rear fenders, "completing" the smooth-flowing lines of Pontiac's distinctive fender styling. By minimizing wheel splash, they keep your car cleaner and help prevent rust.

COMFORT GROUP

Accessories that make driving more comfortable and convenient . . . that's the Comfort Group. All have been carefully selected to give you the utmost in driving pleasure . . . yet cost so little!

NEW WINDSHIELD WASHERS

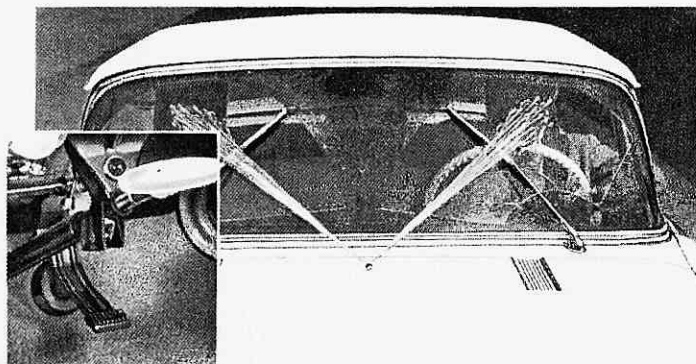

A push of the new foot-controlled lever on the floor throws two streams of water on the windshield and turns on the windshield wipers simultaneously, automatically clearing the windshield of dust, dirt, road splash and insects. Coordinating the windshield washer and windshield wiper is an important safety feature because the driver does not need to remove one hand from the steering wheel to turn on the washer and wiper.

LATEX FOAM SEAT CUSHIONS

Here is resilient foam rubber, one-inch thick, made for the front and rear seat cushions (not on seat backs). The tiny air holes in the cushion "breathe" as pressure is applied, and cushions conform perfectly to body contours. They stay smooth and trim—can't mat, sag or bunch up. Driving fatigue is greatly reduced because latex foam seat cushions help absorb shocks. They can be individually ordered for factory installation—Group K.



COMFORT GROUP



E-Z-EYE TINTED SAFETY GLASS

Now you can have a windshield glass that reduces glare and admits only the soft rays of the sun. It's Pontiac's E-Z-Eye glass . . . the tinted glass that filters out heat rays for cooler car interior and also helps relieve eyestrain. The windshield is tinted in a deepening tone . . . top to bottom . . . cuts down night-driving headlight glare without sacrificing vision. For factory installation only. Order Group I.

PROTECTION GROUP

These accessories can save you money because they will take the brunt of the damage in minor accidents and traffic jars. Built to take rough treatment, they will protect your car, front and back, and eliminate expensive repair bills.

GRILLE GUARD

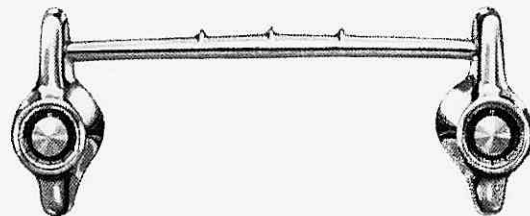

Smartly designed and as modern looking as the new Pontiac itself, this extra-duty grille guard is sturdily made to really "take the bumps". It consists of two modified "bomb type" guards, with the same ornamental center piece that appears on the regular guards. They have upper and lower projections and are joined by a sturdy cross bar having three attractive embossments. Offer ample protection to the grille, yet blend in so well with the grille appearance that it looks like a part of the grille itself. Order this grille guard individually factory installed—Group PX.

REAR BUMPER WING GUARDS

Protect the rear of your car from bumps and scrapes with these new chrome-plated steel wing guards. They cleverly blend into the rear bumper impact bar and wrap around the rear fenders in a wide protective band which diminishes to a narrower band at the rear of the car to end at the rear bumper cross bar for additional protection. Available for Safari and all other models except 860 and 870 Station Wagons—Group PP.

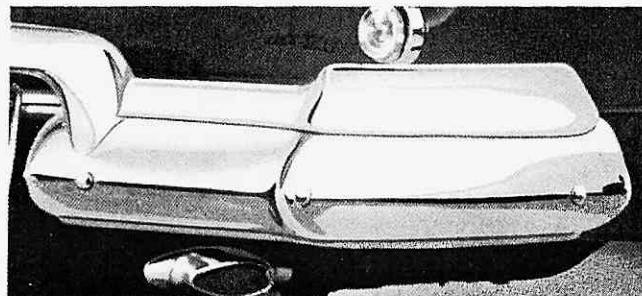

INDIVIDUAL ACCESSORIES

Available for factory and/or dealer installation as specified in the copy for each accessory.



REAR WINDOW DEFROSTER

No more "fogged-up" or frosted rear window when you have this Pontiac accessory installed in your car. Mounted under the rear package shelf, this unit will go to work on fog and frost to clear up the window in a very few minutes. It is controlled by a switch on the instrument panel; and by using the warm air inside the car and blowing it against the rear window, frost and fog are eliminated. The unit is made up of an air chamber and a blower which are compactly built to do the job and yet take up a minimum of space. (Not available on Convertible Coupe and Station Wagons.) Dealer installed only.

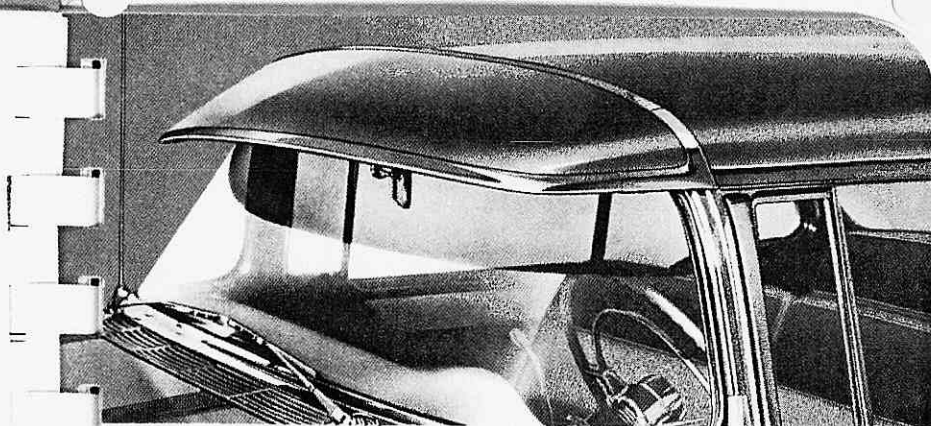

WINDSHIELD SUN VISOR

The Pontiac sun visor forms a trim "steel brim" over the windshield to block out sky glare from the driver's eyes and keep the front seat passengers in the shade. Not only does it relieve eyestrain, but it has been proven that it also keeps the entire interior of the car cooler during summer driving. Front seat passengers are also relieved of the discomfort caused by direct sun rays on the legs. This visor should not be sold as a replacement for the E-Z-Eye glass because obviously they both do a different job. The E-Z-Eye glass cuts down glare, while the sun visor protects front seat passengers from the direct rays of the sun and keeps the car cooler.

This visor, by the way, is beautifully and exclusively designed for the 1956 Pontiac and is made of sturdy all-steel construction and will not rattle or vibrate even at high speeds. Painted to match the car's color and handsomely trimmed in chrome, it is highly recommended for air-conditioned cars to cut down on radiant heat and help the air conditioning unit do a better job. This accessory can be individually ordered for factory installation—Group J, or for dealer installation. (Not available on Convertible Coupe.)

INDIVIDUAL ACCESSORIES

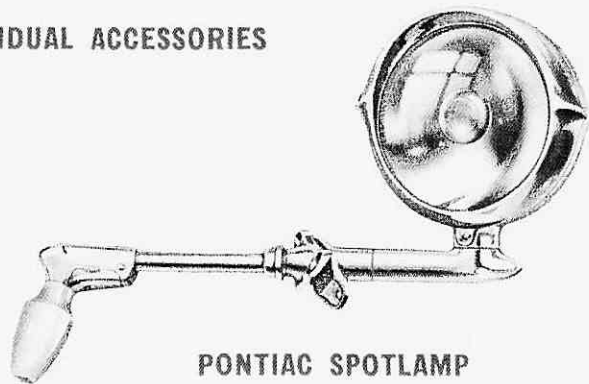

PONTIAC SPOTLAMP

You'll find this accessory an invaluable aid in driving because it is not only a spotlamp, but it may also be used as an outside, rear-view mirror. It has many, many other uses, too, such as an auxiliary headlight should one fail, as an aid in reading road signs or locating house numbers and for general illumination in case of car trouble. The rear-view, no-glare, no-blur, "Cromir" mirror can be adjusted from inside the car simply by turning the spotlamp handle. It is smartly styled, heavily chrome-plated and is mounted through the left door post of the car to reduce vibration. When you order this accessory, ask for the GX Group.

TRAFFIC LIGHT VIEWER



This accessory works on the prism principle to reflect a clear image of overhead traffic lights. It eliminates stooping or squinting because a quick glance in the viewer tells you whether the light is red or green. It is made of plastic with a chrome-plated base mounted on the top of the instrument panel directly ahead of the driver's seat. This accessory comes as a "package" with the windshield sun visor.

HI-FI REAR SEAT SPEAKERS

This new accessory is available for use with either of the two radios offered in 1956. It combines the use of the front speaker with two rear seat speakers located on the rear package shelf to the right and left of center. As a result,

INDIVIDUAL ACCESSORIES

it will now be possible, by use of the rear speaker control switch in combination with the radio tone control knob, to have twenty different sound combinations for ideal selection of hi-fidelity and stereophonic sound reproduction. Here are the five positions which may be selected with the rear speaker control dial: front speaker only, high response rear speaker only, low response rear speaker only, both rear speakers and all speakers (front and rear). By turning the control dial to any of these various positions, reception can be tailored for more pleasant listening for the front and rear seat passengers.

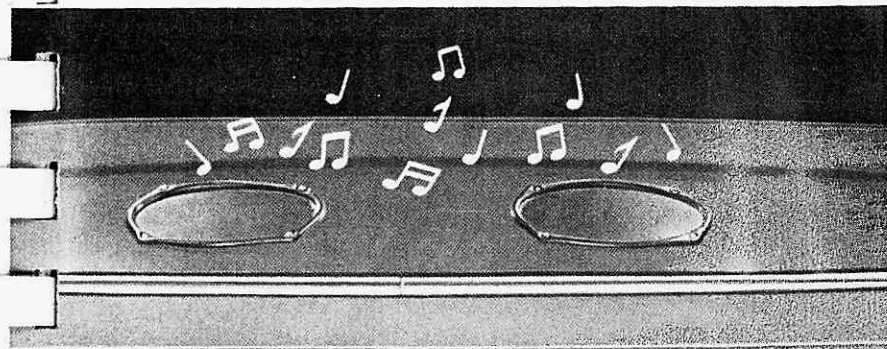

ELECTRIC RADIO ANTENNA

It takes just a flip of the switch and the electric radio antenna goes up to its full height or retracts into the rear fender. It operates while the car is in motion so that if you need better reception while driving through certain areas, it can be had in a flash without the driver's taking his eyes off the road. It also works just as easily when you want to lower it when driving into the garage or under some low-hanging obstruction. While it is in the retracted position your antenna is safer from damage by pranksters and children. Equipped with a powerful motor for quicker response, it has a durable snap-action switch, on the instrument panel below the fuel gauge. Order the EX Group.

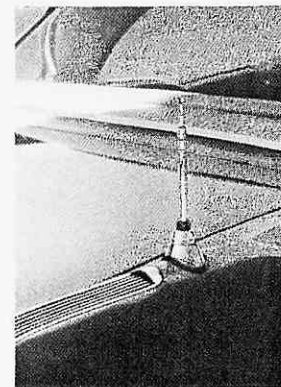

INDIVIDUAL ACCESSORIES

CHROME RINGS

Made expressly for Pontiac 860 models and 870 Station Wagons, these handsome chrome trim rings are bands of bright chromium steel that ring the wheel just inside the tire. They stay on permanently and need not be removed when changing a tire. Their smart appearance dresses up your car and gives it a look of sparkle and zip.

WIRE WHEEL DISCS

Give your new Pontiac a "sports car" flavor by having these stainless steel wire wheel discs installed on your car. They bolt right to the wheel to reduce the possibility of theft and also give a secure installation. Order RR Group.

STAINLESS STEEL WHEEL DISCS

These new wheel discs are made of highly polished stainless steel that are rust and corrosion resistant and give your Pontiac a shiny new appearance. The design for 1956 consists of multi-level graduations ascending to a brushed finished hub. This hub is encircled by numerous fine ridges and, separated from these ridges by a polished ring, are depressed black squares spaced with embossments. Sold separately for 860 models, these wheel discs are standard equipment on the Star Chief and 870 models. (Not available for 860 or 870 Station Wagons.)

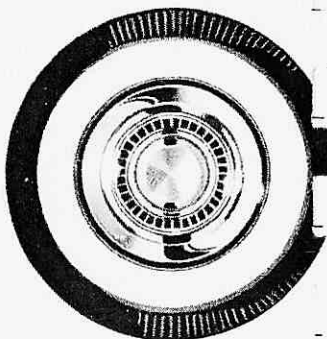
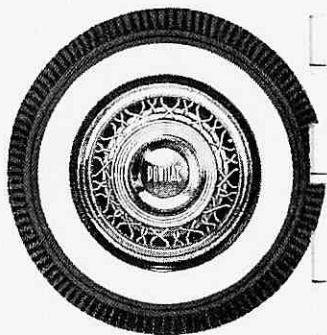
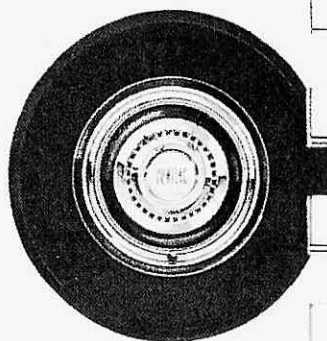

INDIVIDUAL ACCESSORIES

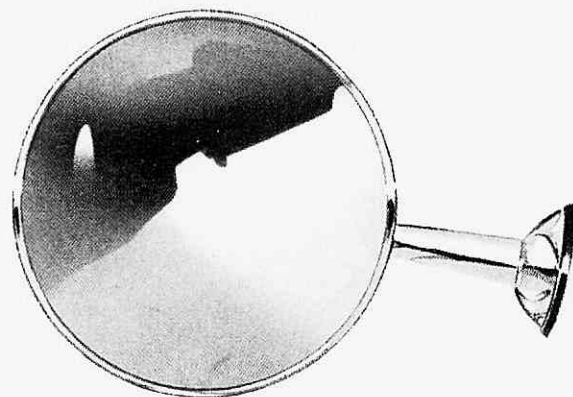

REMOTE-CONTROL OUTSIDE REAR-VIEW MIRROR

This beautiful mirror is made of heavily chrome-plated metal and can be readily adjusted in all kinds of weather from inside the car. Mounted on the door, it operates with a twist of the wrist . . . a fore-and-aft movement for change in mirror aim and change of elevation of the mirror is done by rotating the handle. It is securely attached to eliminate all vibrations, and the "Cromir" front surface mirror glass gives a true, non-glare reflection. This mirror may be ordered in Group GG.

NEW ILLUMINATED CAR COMPASS

A quick glance and you know the exact direction you're traveling, because this compass keeps you on the right road and helps prevent you from making the wrong turns. It has a floating dial design for aircraft accuracy and is illuminated for night use, too. May be mounted at the top-center of the instrument panel, easily adjusted by owner or dealer.



INDIVIDUAL ACCESSORIES

HYDRA-MATIC TRANSMISSION OIL COOLER (860 AND 870 MODELS ONLY)

This Pontiac accessory is highly recommended to Pontiac owners who require above-normal service from the Hydra-Matic transmission. It consists of an external oil cooler, with necessary connections for coolant and oil supply. It is released for use on police cars and taxis, and recommended for rural mail carriers and similar applications involving unusually hard service. By having this Hydra-Matic oil cooler installed, there is less likelihood of the transmission's overheating, and thus may help to avoid costly repair bills and loss of time while car is being serviced. May be ordered as factory-installed accessory or under package number 988520.

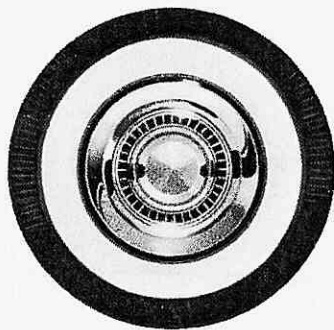

WHITE SIDEWALL TIRES

Add even more beauty to your Pontiac with tubeless white sidewall tires. Protective edge reduces curb scrape . . . keeps sidewalls looking cleaner longer. If 4-ply, 7.10 size is desired, order Group W (except Station Wagons). Order VW Group for 6-ply, 7.10 by 15 size on Sedans and Coupes. For oversize white sidewall tires in 4-ply, 7.60 by 15 size, order the ZW Group.

INDIVIDUAL ACCESSORIES

PONTIAC "KOOL KOOSHION"

These flexible, lightweight seat pads are made of sturdy coil springs which give ample support, and yet allow for the passage of cool air through both the cushion seat and back. "Kool Kooshions" are smartly styled in a neutral shade to go with any Pontiac interior and are covered with ventilated woven fiber that is tough and durable to give extra-long wear.



SEDAN VENTSHADES

You can have your windows open during rainy weather for outside air ventilation when you have these smart Pontiac Ventshades installed on your car. Ventshades are trim, chrome-plated brims that fit snugly over the top of each window and are designed to add to the appearance of your car, as well as being functional. Ventshades not only keep the rain out, but also shade the driver and passengers from the harsh rays of the sun . . . making the car cooler. Easily installed in a few minutes, Ventshades make driving more convenient and comfortable.

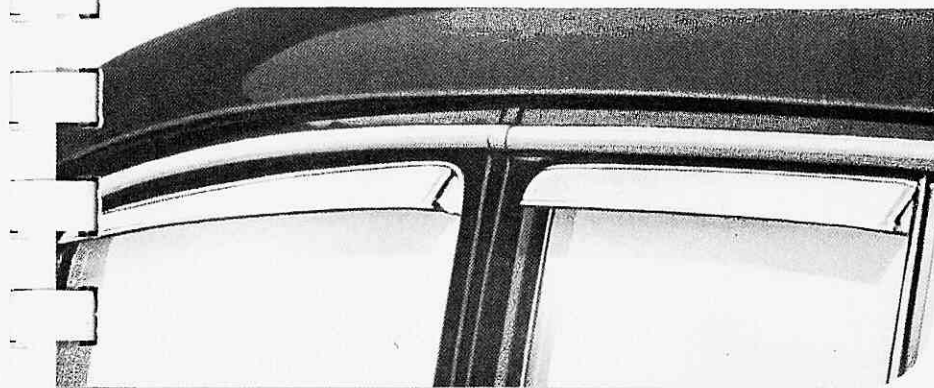

INDIVIDUAL ACCESSORIES

DOOR EDGE GUARDS

This accessory not only dresses up the appearance of your Pontiac, but also prevents nicks and scratches on the edge of the doors. Available for all models, it will keep your car new-looking longer and protect this vulnerable area from damage. The Pontiac door edge guard is made of polished stainless steel that won't rust or corrode. Can be quickly installed without drilling any holes.

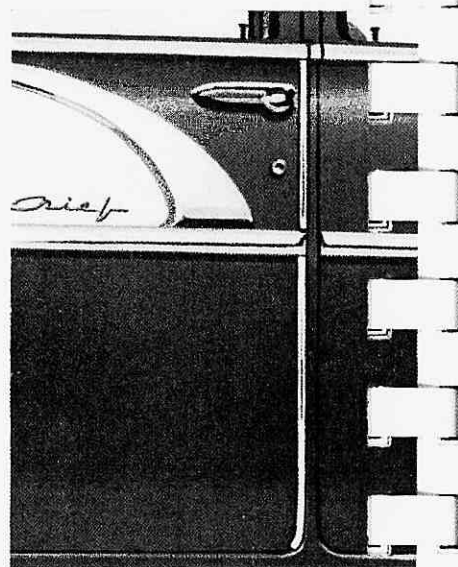

TISSUE DISPENSER

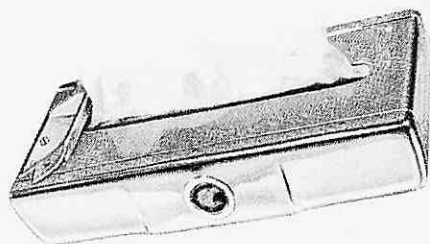

With Pontiac's handy tissue dispenser right at your fingertips, you can eliminate frantic searching for tissues in glove compartment or purse. They are ideal for children's accidents, cleaning eyeglasses, and many other uses. This handsome dispenser fits neatly under the instrument panel and, when needed, swings out for easy accessibility and swings back to its out-of-the-way position with a touch of the hand. Without a doubt, this is one of the handiest accessories you could have in your new Pontiac.

INDIVIDUAL ACCESSORIES

DOOR HANDLE GUARD

Smartly styled and sturdily made, door handle guards eliminate unsightly nicks and scratches around the door handle.

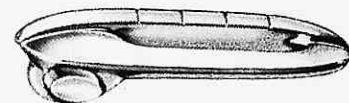

INVISIBLE INSECT SCREEN

This screen cannot be seen from the outside because it is installed behind your Pontiac grille and completely covers the radiator openings. Made of fine mesh screen, it catches insects, prevents clogging and reduces the possibility of overheating the cooling system in insect areas. Because of its location, the screen will not detract in any way from the beauty and appearance of your Pontiac grille and yet it is easily removed for cleaning. In fact, you can clean it yourself in a matter of minutes with a broom and plain water from the garden hose.

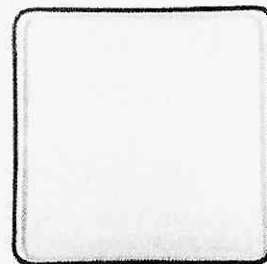

FOLD-AWAY UMBRELLA



No matter where you drive you can always have an umbrella with you, if you keep one of these Pontiac fold-away umbrellas in your glove compartment. No more being caught in the rain . . . no more wet clothing or extra dry-cleaning bills, because this umbrella gives you all the protection that an ordinary umbrella offers, and yet fits snugly in the glove compartment. Choice of two colors in long-wearing, wrinkle-resistant nylon or four colors in inexpensive, lustrous rayon . . . both offering complete rain protection wherever you go.

INDIVIDUAL ACCESSORIES

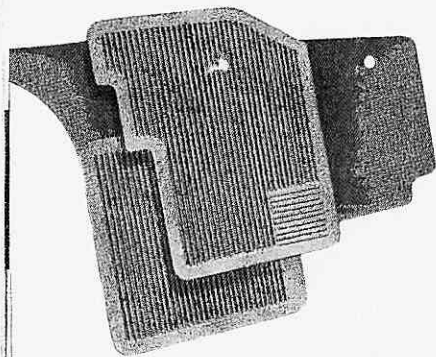

RUBBER FLOOR MATS

Your front and rear floor mats will stay new-car clean when you see these new "contour" rubber floor mats. They prevent unsightly rain and snow stains and save wear and scuffing of the floor mats underneath. Choice of many new colors to go with the car interior.

FUEL DOOR LOCK

Prevent harmful damage to your gas tank from children's pranks by getting this inexpensive Pontiac accessory. It's low-cost insurance against gasoline siphoning and theft, and can be installed in a matter of minutes. The lock can be coded to either your ignition or trunk key, and you're free from worry about damage and theft.

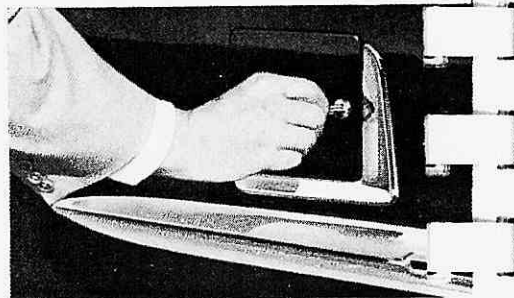

CONTINENTAL TIRE KIT

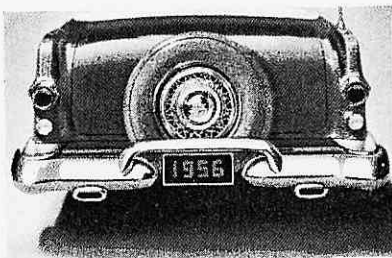

Give your car a touch of distinction and elegance with a Pontiac continental tire kit. Sturdily mounted, it makes the full trunk area easily accessible. A slight pull of the release handle and the continental tire moves aside and away from the trunk for easy access to trunk compartment. Move tire back in place and it locks in position automatically.

INDIVIDUAL ACCESSORIES

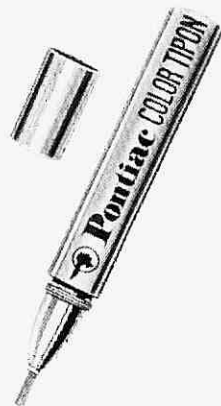

PONTIAC COLOR "TIPON"

Now you can touch up unsightly nicks and scratches yourself with this amazing little Pontiac Tipon. A lipstick-like brush dispenser, this Tipon contains an ample supply of Pontiac paint that comes in various colors to match your car exterior. Colors are available for the new 1956 models and late-model Pontiacs, too.

"AUTRONIC-EYE" AUTOMATIC HEADLIGHT CONTROL



Forget about dimming your headlights . . . the Pontiac "Autronic-Eye"® does it for you! When another vehicle approaches, your headlights are dimmed automatically at a safe distance. When the vehicle passes, your headlights return to bright. A floor switch lets you override if you wish to signal with your brights.

ELECTRIC CLOCK

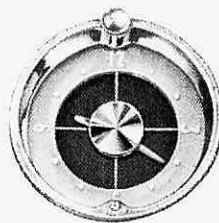

You'll always be on time for appointments when you have this beautiful electric clock in your Pontiac. The numerals are easy to read both day and night, because in the dark the white numerals are edge-lit with white illumination. The small knob above the clock face regulates the hands, and the entire clock is conveniently installed to the right of the glove compartment.

INDIVIDUAL ACCESSORIES

PONTIAC ANTIFREEZE

Keep your car free from freeze-ups with Pontiac factory-installed, engineer-approved, all-winter or methanol anti-freeze. You may choose either methanol or all-winter type ethylene glycol depending on which you prefer. For factory installation of ethylene glycol order Group OX (11 quarts) or Group OO (6½ quarts). Methanol will be installed in season unless the all-winter ethylene glycol is specifically ordered for factory installation.

PONTIAC UNDERCOATING

Every new Pontiac owner should be urged to get a Pontiac engineer-approved undercoating for his car. It protects against rust and corrosion, insures quieter operation and increases the car's resale value.

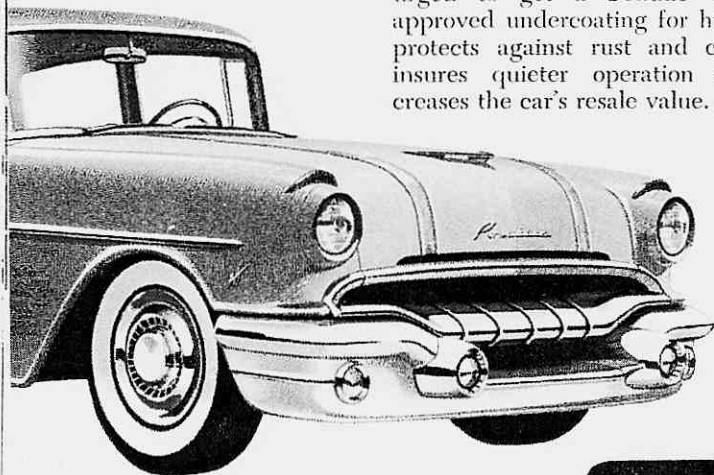

REMINGTON ELECTRIC SHAVER

The Remington De Luxe 653 Model Shaver is ideal for the busy traveling man. Specifically designed to operate equally well on 12-volt or 110-volt current, this combination gives you two shavers in one—ready for instant use either plugged in the cigar lighter receptacle or in any home outlet.



INDIVIDUAL ACCESSORIES

THERMASTER REFRIGERATOR

Perfect for traveling long distances and for outings, this refrigerator keeps food and beverages cold for hours. It has a red baked-enamel finish with polished aluminum cover, and boasts a drain spigot and attached bottle opener. Measures 21" x 10" x 12" in size.

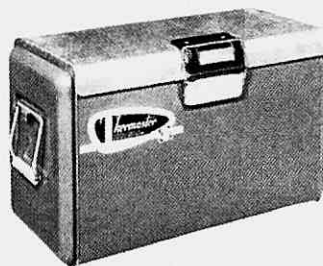

PURSE HANGER

Purses may be hung up out of the way when this handy accessory is in your Pontiac. Consisting of a sturdy black plastic hanger with contrasting red plastic medallion, it can be installed in just a few minutes. For Station Wagons and Catalina models, hanger edge is slipped snugly in place under the window molding.

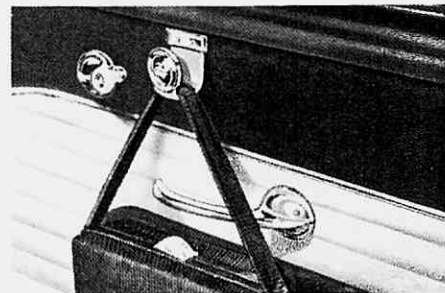

FLAMINGO TOTER

Here is a real convenient Toter for all your picnic and traveling requirements. The four-gallon capacity assures room for everything, and the fiber glass insulation keeps foods hot or cold for hours. The removable aluminum tray keeps foods dry, while beverages below can be cooled in ice. This tray may also be used as a skillet or pan, if desired.



INDIVIDUAL ACCESSORIES



PONTIAC SEAT COVERS

For 1956, you will be offered a choice of three different materials in beautiful new patterns. The covers available are Oxford Nylon (shown above) in Blue, Red, Green, Brown or Grey in assorted patterns; Tricot Nylon in solid Blue, Red, Green or Gold; and Plastic in Blue, Red or Green in plaid pattern. All can be installed quickly and easily.

OXFORD NYLON: Blue, Red, Green, Brown or Grey

	4-Door Sedans and Catalinas	2-Doors	2-Door Catalina
Complete Set	613S11	613S23	613S24
Complete Front Seat	613S11A	613S23A	613S24A
Front Cushion Only	613S11B	613S23B	613S24B
Complete Rear Seat	613S11RS	613S23RS	613S24RS

TRICOT NYLON: Blue, Red, Gold, Green—Solid Colors

	4-Door Sedans and Catalinas	2-Door Sedans and Catalinas
Complete Set	653F11	653F24
Complete Front Seat	653F11A	653F24A
Front Cushion Only	653F11B	653F24B
Complete Rear Seat	653F11RS	653F24RS

INDIVIDUAL ACCESSORIES

PLASTIC: Blue, Red or Green Plaid Pattern

	4-Door Sedans and Catalinas	2-Doors	2-Door Catalinas
Complete Sets Only	645 F 11	645 F 23	645 F 24

ADDITIONAL OPTIONAL EQUIPMENT

Available for Factory Installation

HILLS AXLE—Order the U Group
All Synchronesh—39-10

BLACK SIDEWALL TUBELESS TIRES—ORDER THE V GROUP
7.10 x 15—6-Ply
All except Station Wagons

WHITE SIDEWALL TUBELESS TIRES—ORDER THE W GROUP
7.10 x 15—4-Ply
All except Station Wagons

WHITE SIDEWALL TUBELESS TIRES—ORDER THE VW GROUP
7.10 x 15—6-Ply
All except Station Wagons

LOW-COMPRESSION ENGINE—ORDER THE Y GROUP
Synchronesh Only

HEAVY-DUTY PLATE BATTERY—ORDER THE YX GROUP

OVERSIZE TUBELESS TIRES—ORDER THE Z GROUP
7.60 x 15—4-Ply
Standard on all Station Wagons

OVERSIZE WHITE SIDEWALL TUBELESS TIRES—
ORDER THE ZW GROUP
7.60 x 15—4-Ply
All Models